



INFRARED CAMERAS

The most versatile infrared cameras in the world

innovative infrared technology

The Compact- and the Precision Line offer imaging infrared temperature measuring devices for all applications

Advantages of the Xi Compact Line

- Motor focus
- Compact industrial imager for temperature measurements from -20 to $900\text{ }^{\circ}\text{C}$
- Autonomous operation with automatic spot finder and direct analog output – ideal for OEM use (Xi 80)
- Direct Ethernet and RS485 interface (Xi 80)



Automatic hotspot search

Objects can be thermally analyzed and hot or cold spots can be found automatically.

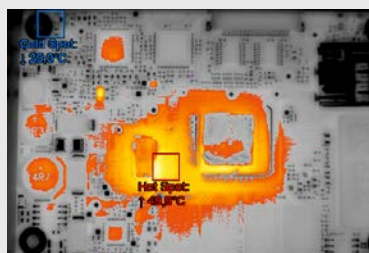

Advantages of the PI Precision Line

- Interchangeable lenses
- Suited for fast processes (up to 1 kHz)
- High thermal sensitivity (up to 40 mK NETD)
- High optical resolution (up to 640 x 480 Pixel)
- Laser blocking filters
- Temperature measuring ranges from -20 to $2000\text{ }^{\circ}\text{C}$
- Different spectral ranges (500 nm / 1 μm / 7.9 μm / 7,5 – 13 μm)

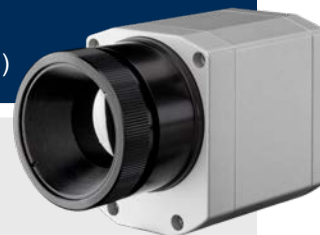

Fast measurements

Temperature distributions on a surface can be precisely recorded at millisecond intervals.

A drop of milk falling into a cup of coffee.

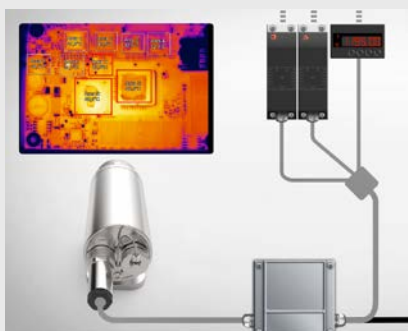
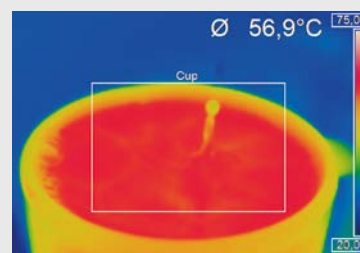

Autonomous operation with direct analog output

Up to 9 freely definable measuring areas may be used as analog outputs when using an external process interface.

Simple process integration

- Software Development Kit (SDK) for integration of the camera into customer-specific software via Dynamic Link Library (DLL) or COM-Port.
- Interfaces to LabView and MATLAB are included as well

optris® Microscope optics

The interchangeable and focusable microscope optics enable electrical testing and thermal analysis of smallest components at the same time - with an optical resolution of up to 28 μm . Fast processes can easily be monitored with a frame rate of up to 125 Hz and, with the recording of radiometric video sequences and images, be saved for later analysis.



optris® Xi 80 / Xi 400

INFRARED CAMERAS
FOR OEM USE

Compact spot finder IR camera

- Industrial imager for precise temperature measurements from -20 to 900 °C
- Rugged, compact imager with motor focus
- Autonomous operation with automatic spot search and direct analog output
- 80 Hz frame rate for the monitoring of fast thermal processes
- Extensive ready-to-use package for an attractive price – including versatile image processing software and connection cables

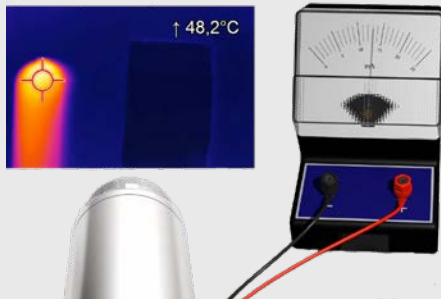

Integrated spot finder function

The integrated spot finder function allows for precise temperature measurements of moving objects - without having to readjust the sensor. The camera figures it out on its own, without being connected to a PC.

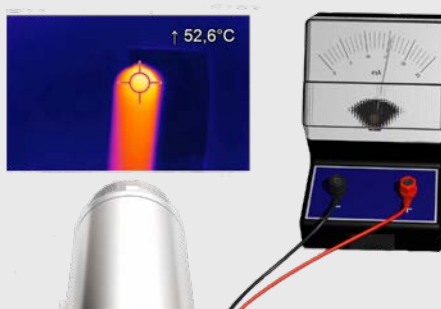

Pyrometer or camera?

The Xi series is a fusion of a rugged, compact pyrometer and a modern IR camera. Thanks to analog and digital outputs as well as the option to process up to nine freely definable measuring areas using an external process interface, the Xi camera is perfectly suited for OEM applications.

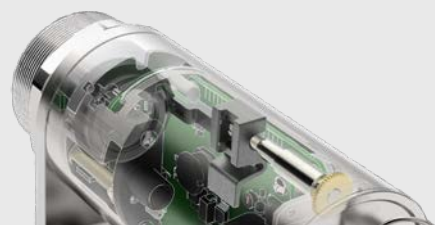
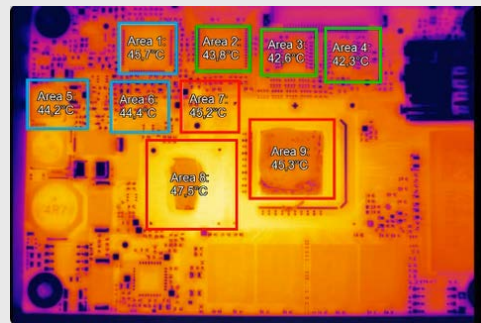

Motor focus simplifies handling

Both Xi models are equipped with a motorized focus. The free PIX Connect software enables a remote focusing from the distance.

optris® PI 160

INFRARED CAMERA
WITH 120 Hz FRAME RATE

Small camera for fast processes

- Outstanding value for money
- Very good thermal sensitivity of 40 mK
- Thermal image up to 120 Hz
- Detector with 160 x 120 pixels
- Compact design (dimensions: 45 x 45 x 62 mm)
- Includes license-free analysis software and full SDK



Surface measurements in industrial application

The optris® PI 160 infrared camera is always used when temperature monitoring of surfaces is required and the single point measurement of pyrometers is no longer sufficient.

Nowadays surface measurements are essential in the automotive field, in plastic applications and in the solar industry.

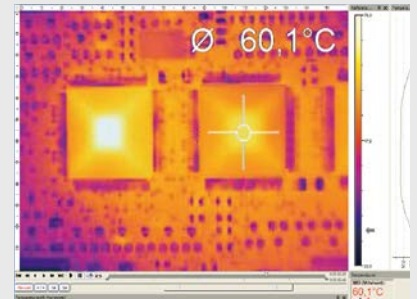

Hand as measuring object:
measurement field size 240 mm x 180 mm
Pixel size 1.5 mm

160 x 120 pixels

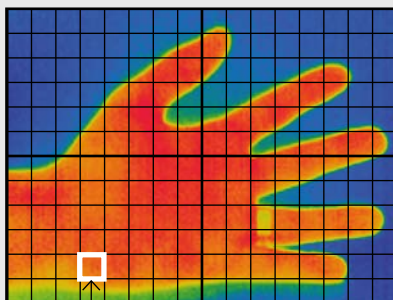

10 x 10 pixels = 225 mm²

Suitable lenses for every measurement distance

Same measurement field size at different measurement differences:

- Telephoto lens (6° x 5°):
2.13 m measurement difference
- Standard lens (23° x 17°):
0.6 m measurement difference
- Wide-angle lens (41° x 31°):
0.32 m measurement difference
- Wide-angle lens (72° x 52°):
0.17 m measurement difference



Application examples, e.g. in the automotive sector:

www.optris.global/automotive

optris® PI 200 / PI 230

INFRARED CAMERA WITH BI-SPECTRAL TECHNOLOGY

Two cameras in one compact device

- BI-SPECTRAL technology
- Time-synchronized visual image recording at up to 32 Hz (640 x 480 pixels)
- Real image camera is highly sensitive in low-light conditions
- Thermal images to 128 Hz (160 x 120 pixels)
- Compact design (dimensions: 45 x 45 x 62 mm)
- Includes license-free analysis software and full SDK

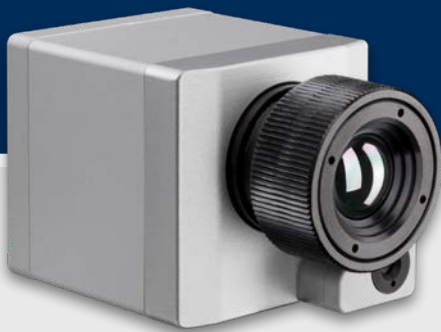

BI-SPECTRAL Technology

With the help of BI-SPECTRAL technology a **visual image (VIS)** can be combined with a **thermal image (IR)** and plotted synchronistically:

Surveillance mode:

Easy orientation at the measuring point through separate display of the visual picture.

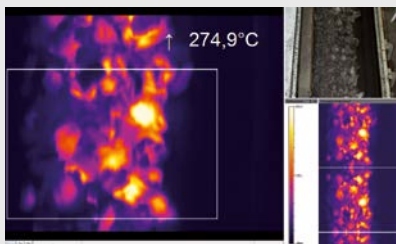

Monitoring of a carbon ribbon.

Crossfade mode:

Highlight critical temperatures by means of crossfade (transparency from 0 to 100 %) or by means of superimposition of defined temperature fields (thresholds).

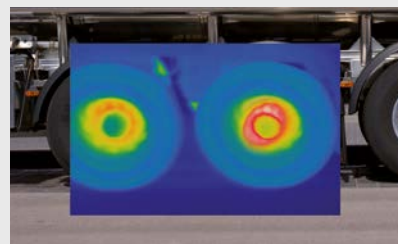

Measurement of the brake temperature in superimposed image

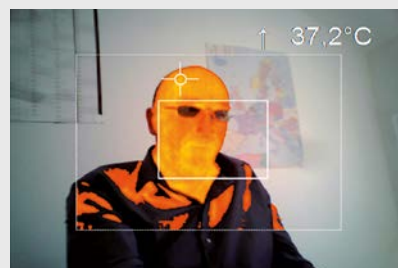

Cross fade of a VIS image above 35 °C

optris® PI 400i

INFRARED CAMERA

WITH HIGH OPTICAL RESOLUTION

The smallest camera in its class

- The smallest camera in its class (45 x 45 x 60 – 75 mm)
- Very good thermal sensitivity at 75 mK
- Thermal image recording up to 80 Hz
- Interchangeable lenses & industrial accessories
- Lightweight (195 g incl. lens)
- Detector with 382 x 288 pixels
- Includes license-free analysis software and full SDK

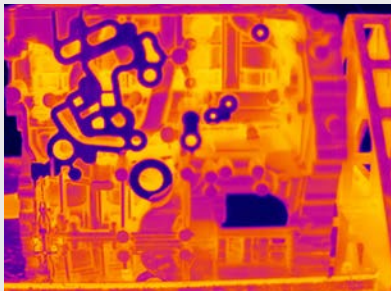

High performance for a wide range of applications

The high-performance optris® PI 400i infrared camera has a wide range of uses in industry. For example, thermal image shots help to monitor processes and ensure the quality of manufactured products in the automotive field in particular, in the manufacturing of plastics as well as in the semiconductor and photovoltaic industry.

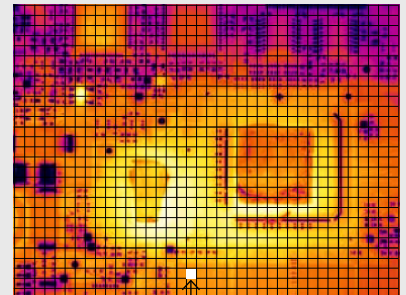

382 x 288 Pixel | 10 x 10 Pixel = 40 mm²

SMD chip as measurement object:
measurement field size: 240 mm x 180 mm,
pixel size: 0.63 mm

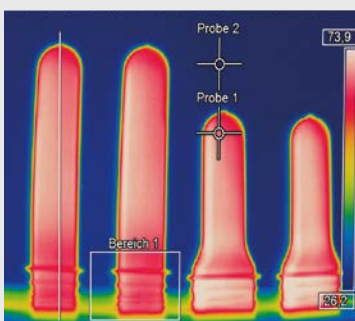

Thermal image shots of preforms in PET bottle production

80 Hz recordings with full pixel resolution

The display and recording of thermal images at full optical resolution can be done at high measurement speeds of 80 frames per second.



Application examples, e.g. in the plastics industry:

www.optris.global/plastics

optris® PI 450i

INFRARED CAMERA WITH VERY HIGH THERMAL SENSITIVITY

Detection of minimal temperature differences

- The smallest camera in its class (45 x 45 x 60 – 75 mm)
- Exceptional thermal sensitivity at 40 mK
- Thermal image recording up to 80 Hz
- Interchangeable lenses & industrial accessories
- Lightweight (195 g incl. lens)
- Detector with 382 x 288 pixels
- Usable at ambient temperatures of up to 70 °C without the need for additional cooling
- Includes license-free analysis software and full SDK



Highest temperature resolution of 40 mK

With an optical resolution of 40 mK, the optris® PI 450i is used for measuring the most subtle temperature differences, e.g. in the quality control of products or in preventive medicine.

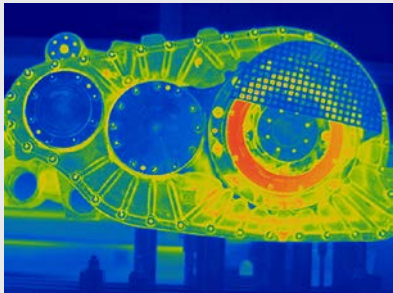

Application example in the medical sector

Due to the very high resolution of the optris® PI 450i, even veins can be made visible under the skin.

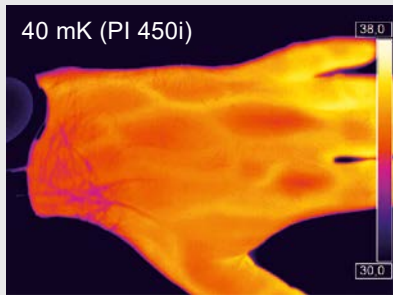
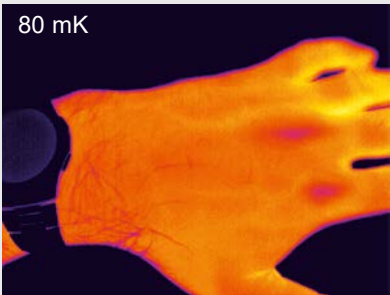

optris® PI 640

THERMOGRAPHY
IN VGA RESOLUTION

The smallest VGA infrared camera in the world

- 640 x 480 pixels
- Radiometric video recording at 32 Hz / 125 Hz in subframe-mode (640 x 120 pixels)
- Compact size of 46 x 56 x 90 mm
- Lightweight (320 g incl. lens)
- Includes license-free analysis software and full SDK

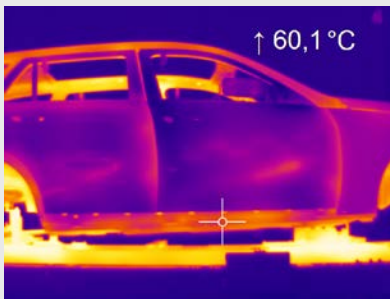
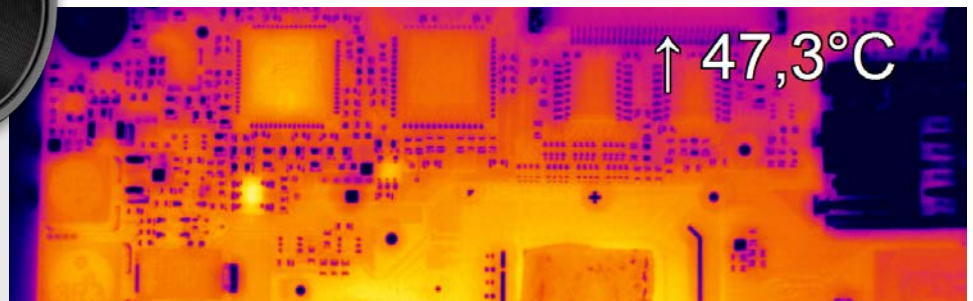
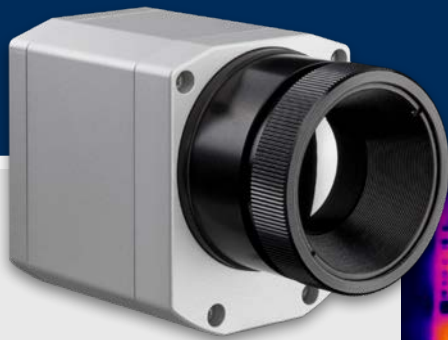

Razor sharp infrared pictures and videos for process optimization

With a casing size of only 46 x 56 x 90 mm and a weight of 320 grams (incl. lens), the optris® PI 640 is among the most compact infrared cameras on the market.

The high-definition optris® PI 640 infrared camera is best used in applications where finest thermal details matter.

It significantly contributes to process optimization in both research and development and in industry.

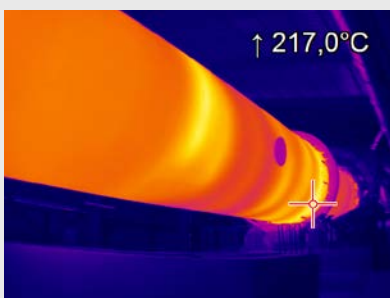
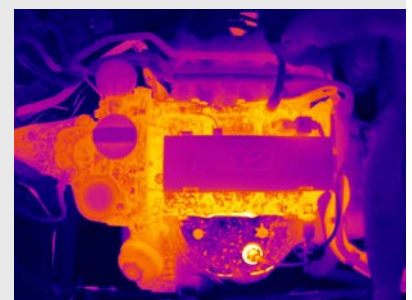

Application examples, e.g. the early detection of fires in garbage bunkers:

www.optris.global/fire-prevention

optris® PI 450 G7 / PI 640 G7

INFRARED CAMERAS FOR SURFACE TEMPERATURE MEASUREMENTS ON GLASS WITH LOW REFLECTIONS

High-resolution thermography for the glass industry

- Usable at ambient temperatures of up to 70 °C without the need for additional cooling
- With an integrated filter for the spectral range of 7.9 µm
- Compact size of 46 x 56 x 90 mm
- Frame rate up to 125 Hz
- Line scan function through license-free analysis software optris® PIX Connect
- Max. scan angle of 111 °C with 800 pixels per line



Exact temperature measurements on glass surfaces via line-scan camera function

The temperature of glass is best measured in the range of spectral absorption bands. For this purpose the optris® PI 450 / PI 640 G7 has an integrated 7.9 µm filter which enables an anechoic IR surface temperature measurement. Its compact size makes the optris® PI 450 / PI 640 G7 particularly suitable for use in confined spaces and for installation in industrial facilities. The infrared camera is fully operational at ambient temperatures of up to 70 °C without the need for cooling. With an imaging frequency of up to 125 Hz, glass products can be continuously tested, even in fast processing.

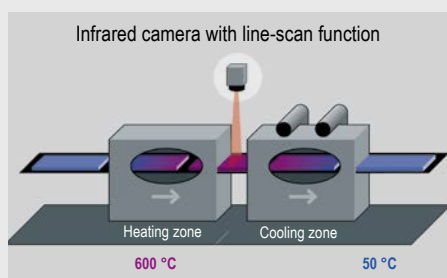

Construction of a glass tempering plant.



Application examples for the glass industry:

www.optris.global/glass

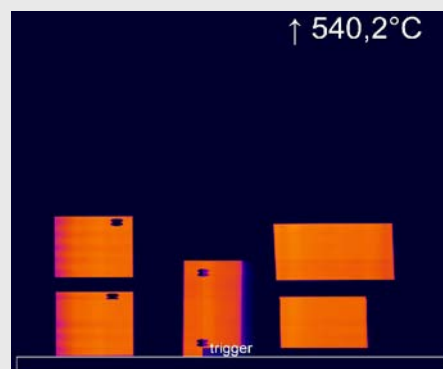

Glass panes between heating and cooling zone.

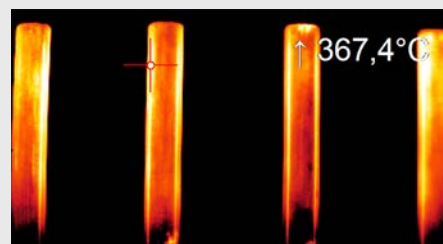

Glass tube manufacturing.



Hot-spot measurement in the production of glass bottles.

optris® PI 05M / PI 08M / PI 1M

INFRARED CAMERAS FOR
THE SHORTWAVE DOMAIN

Ultra compact infrared cameras for the metal industry

- Highly dynamic CMOS detector with an optical resolution of up to 764 x 480 pixels
- Very large temperature measurement ranges (without sub-ranges) of 450 °C to 1800 °C (PI 1M) and of 900 °C to 2450 °C (PI 05M)
- Frame rates and linescanning function up to 1 kHz for fast processes
- Real-time output of 8x8 pixels with 1 ms response time
- Includes license-free analysis software and full SDK
- New: PI 08M - Ideally suited for all laser processing applications with solid-state lasers in NIR through excellent blocking of radiation



Smart temperature measurement – Innovative and fast

The IR cameras optris® PI 05M, PI 08M and PI 1M are specially suited for measuring the temperature of metals, as these exhibit a distinctly higher emissivity at the short measurement wavelength of 500 nm and 1 µm than at measurements in the previously conventional wavelength range of 8 – 14 µm.

Especially the new spectral range of 500 nm enables for more precise measurements at changing emissivities and is less sensitive to atmospheric influences. Thus, the PI 05M is ideally suited for temperature measurements of molten metals. A direct 1 ms analog output allows both camera models a readout of a freely selectable 8x8 pixel region in real-time.

The use of these new image sensors allows a large dynamic range for temperature measurement so that the previously necessary use of relatively many and narrowly defined sub-ranges is no longer required. The PI 1M's and PI 05M's two-dimensional temperature measurement opens up new options compared to the usual spot measurement of pyrometers..

Thanks to the large measurement temperature range of 450 to 2450 °C, the optris® PI 05M and PI 1M IR camera satisfies practically all demands in the fields

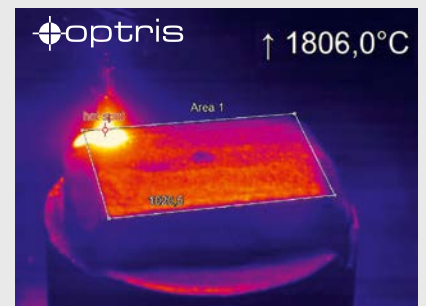

Measurement during laser welding process

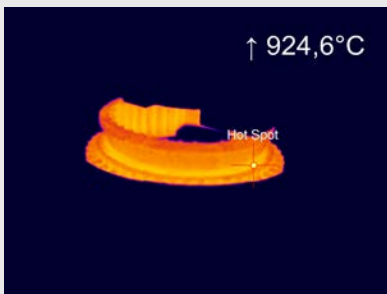

Induction heating

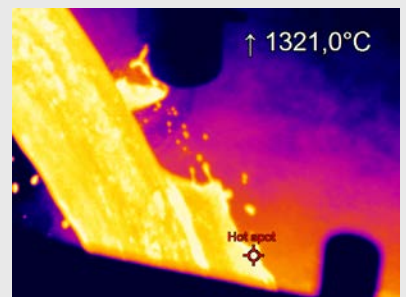

Measurement of a pouring stream.

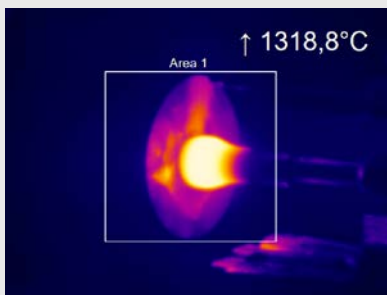

Electrical upsetting.



Application examples for the metal industry:

www.optris.global/metal

Microscope optics for the inspection of electronic boards

- Exchangeable, focusable optics for most flexible use of the camera
- Analysis of small chip level components down to 28 μm
- Hands-free operation for simultaneous testing and IR imaging
- Frame rates up to 125 Hz allow inspection of fast processes (like pulsed laser diodes)
- Radiometric video or tiff recording with ± 2 °C measurement accuracy
- License-free analysis software and complete SDK included

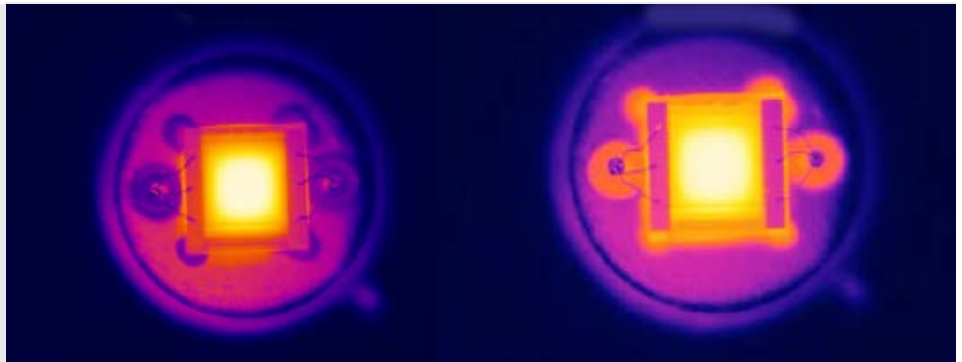

High resolution microscope optics for test & measurement

Besides the regular lenses, the PI 640 features a special microscope optics. Apart from detailed macro recordings of individual components, these also allow recordings of the entire circuit board.

High resolution macro shots of individual components are possible with a spatial resolution of 28 μm , the distance between the measurement object and camera is variable and can be adjusted between 80 and 100 mm.

The high-quality thermal and geometric detail resolution of the infrared cameras ensures precise functional testing of electronic products, as even the smallest temperature differences to be accurately detected.

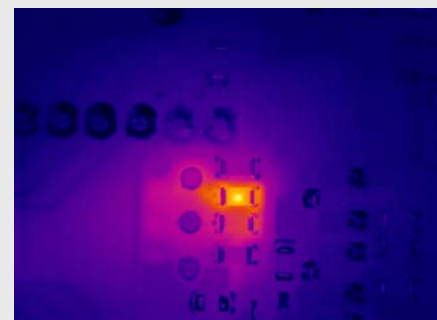
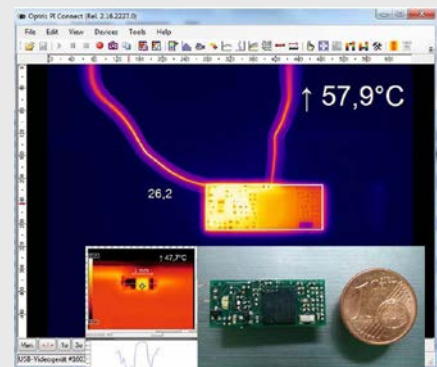

Recording of a circuit board with the optris® PI 640



Application examples for the analysis of
electronic boards:

www.optris.global/electronics-industry

optris® Xi Infrared cameras – The Compact Line

Optics calculator: www.optris.global/optics-calculator

Compact spot finder
IR camera or applications in
rough industrial environments



Basic model	Xi 80	Xi 400
Type	IR	IR
Detector	FPA, uncooled (34 µm pitch)	FPA, uncooled (17 µm pitch)
Optical resolution	80 x 80 pixels	382 x 288 pixels
Spectral range	8 – 14 µm	8 – 14 µm
Temperature ranges	–20 ... 100 °C 0 ... 250 °C (20) 150 ... 900 °C ¹⁾	–20 ... 100 °C 0 ... 250 °C (20) 150 ... 900 °C ¹⁾
Frame rate	50 Hz	80 Hz / 27 Hz
Optics (FOV)	30° (f = 5.1 mm) 12° (f = 12.7 mm) 55° (f = 3.1 mm) 80° (f = 2.3 mm)	29° x 22° (f = 12.7 mm) 18° x 14° (f = 20 mm) 53° x 38° (f = 7.7 mm) 80° x 54° (f = 5.7 mm)
NEW: Microscope optics	–	18° x 14° (f = 20 mm), smallest measuring spot: 90 µm
Focus	Manual motor focus	Manual motor focus
Optical resolution (D:S)	190:1 (12° lens)	390:1 (18° lens)
Thermal sensitivity (NETD)	100 mK	80 mK
Accuracy	±2 °C or ±2 %, whichever is greater	±2 °C or ±2 %, whichever is greater
PC interfaces	USB 2.0 / Ethernet (100 Mbit/s) / PoE / RS485 ²⁾	USB 2.0 / optional USB to GigE (PoE) interface
Direct in-/inputs	1x 0/4 – 20 mA output 1x input (analog 0 – 10 V or digital max. 24 V); optically isolated	–
Standard Process Interface (PIF)	–	1x 0–10 V input 1x digital input (max. 24 V) 1x 0–10 V output
Industrial Process Interface (I-PIF)	3x 0/4 – 20 mA or 0–10 V outputs, 3x inputs (analog 0 – 10 V or digital max. 24 V), 3x relays (0 – 30 V) / 400 mA), 1x fail-safe relay; stackable up to 3 PIFs; optically isolated	2 x 0–10 V inputs, 1x digital input (max. 24 V) 3 x 0–10 V outputs, 3 x relays (0–30 V / 400 mA), 1x fail-safe relay
Cable length (USB)	USB: 1 m (standard), 3 m, 5 m, 10 m and 20 m Ethernet / RS485: 100 m	USB: 1 m (standard), 3 m, 5 m, 10 m and 20 m
Ambient temperature	0 ... 50 °C	0 ... 50 °C
Size / class	Ø 36 x 90 mm (M30x1 thread) / IP 67 (NEMA 4)	Ø 36 x 100 mm (M30x1 thread) / IP 67 (NEMA 4)
Weight	185 g	200 g
Shock/ Vibration ³⁾	IEC 60068-2-27 (25G and 50G) / IEC 60068-2-6 (sinus shaped), IEC 60068-2-64 (broadband noise)	IEC 60068-2-27 (25G and 50G) / IEC 60068-2-6 (sinus shaped), IEC 60068-2-64 (broadband noise)
Power supply	USB / PoE / 5-30 VDC	via USB
Scope of supply (standard)	<ul style="list-style-type: none"> • Xi camera • USB cable (1 m) • Cable for in-/inputs (1 m) with terminal block • Mounting bracket with tripod thread, mounting nut • Software package optris® PIX Connect • Quick start guide 	<ul style="list-style-type: none"> • Xi camera • USB cable (1 m) • Cable for in-/inputs (1 m) with terminal block • Mounting bracket with tripod thread, mounting nut • Software package optris® PIX Connect • Quick start guide

¹⁾ Accuracy effective starting at 150 °C

²⁾ Direct in- and outputs are not available while using the RS485 interface

³⁾ For further details see operator's manual

optris® PI Infrared cameras

– The Precision Line

 Optics calculator: www.optris.global/optics-calculator

Compact infrared cameras for fast online applications – including line scanner				
Basic model		PI 160	PI 200 / PI 230	PI 400i / PI 450i
Type		IR	BI-SPECTRAL	IR
Detector		FPA, uncooled (25 µm pitch)	FPA, uncooled (25 µm pitch)	FPA, uncooled (17 µm x 17 µm)
Optical resolution		160 x 120 pixels	160 x 120 pixels	382 x 288 pixels
Spectral range		8 – 14 µm	8 – 14 µm	8 – 14 µm
Temperature ranges		–20 ... 100 °C, 0 ... 250 °C, (20) 150 ... 900 °C ¹⁾ , 200 ... 1500 °C (Option) ³⁾	–20 ... 100 °C, 0 ... 250 °C, (20) 150 ... 900 °C ¹⁾ , 200 ... 1500 °C (Option) ³⁾	–20 ... 100 °C, 0 ... 250 °C, (20) 150 ... 900 °C ¹⁾ , 200 ... 1500 °C (Option) ³⁾
Frame rate		120 Hz	128 Hz ⁴⁾	80 Hz / switchable to 27 Hz
Optics (FOV)		23° x 17° / f = 10 mm or 6° x 5° / f = 35.5 mm or 41° x 31° / f = 5.7 mm or 72° x 52° / f = 3.3 mm	23° x 17° ²⁾ / f = 10 mm or 6° x 5° / f = 35.5 mm or 41° x 31° ²⁾ / f = 5.7 mm or 72° x 52° / f = 3.3 mm	18° x 14° / f = 20 mm or 29° x 22° / f = 12.7 mm or 53° x 38° / f = 7.7 mm or 80° x 54° / f = 5.7 mm
Thermal sensitivity (NETD)		40 mK with 23° x 17° FOV / F = 0.8 0.3 K with 6° x 5° FOV / F = 1.6 0.1 K with 41° x 31° FOV and 72° x 52° FOV / F = 1	40 mK with 23° x 17° FOV / F = 0.8 0.3 K with 6° x 5° FOV / F = 1.6 0.1 K with 41° x 31° FOV and 72° x 52° FOV / F = 1	PI 400i: 75 mK with 29°, 53°, 80° FOV PI 450i: 40 mK with 29°, 53°, 80° FOV o.g. Optics: F = 0.9 PI 400i: 0.1 K with 18° FOV / F = 1.1 PI 450i: 60 mK with 18° FOV / F = 1.1
Option visual camera (BI-SPECTRAL only)		–	Optical resolution: 640 x 480 pixels Frame rate: 32 Hz ⁴⁾ Optics (FOV): PI 200: 54° x 40°, PI 230: 30° x 23°	–
Accuracy		±2 °C or ±2 %, whichever is greater	±2 °C or ±2 %, whichever is greater	±2 °C or ±2 %, whichever is greater
PC interfaces		USB 2.0 / optional USB to GigE (PoE) interface	USB 2.0 / optional USB to GigE (PoE) interface	USB 2.0 / optional USB to GigE (PoE) interface
Process-Interface (PIF)	Standard PIF	1x 0–10 V input, 1x digital input (max. 24 V), 1x 0–10 V output	1x 0–10 V input, 1x digitaler input (max. 24 V), 1x 0–10 V output	1x 0–10 V input, 1x digital input (max. 24 V), 1x 0–10 V output
	Industrial PIF (optional)	2x 0–10 V inputs, 1x digital input (max. 24 V), 3x 0–10 V outputs, 3x relays (0–30 V / 400 mA), 1x fail-safe-relays	2x 0–10 V inputs, 1x digital input (max. 24 V), 3x 0–10 V outputs, 3x relays (0–30 V / 400 mA), 1x fail-safe-relays	2x 0–10 V inputs, 1x digital input (max. 24 V), 3x 0–10 V outputs, 3x relays (0–30 V / 400 mA), 1x fail-safe relays
Ambient temperature (T _{Amb})		0 ... 50 °C	0 ... 50 °C	PI 400i: 0 °C ... 50 °C / PI 450i: 0 °C ... 70 °C
Storage temperature		–40 ... 70 °C	–40 ... 70 °C	PI 400i: –40 ... 70 °C PI 450i: –40 ... 85 °C
Relative humidity		20–80 %, non-condensing	20–80 %, non-condensing	20–80 %, non-condensing
Size / Class		45 x 45 x 60 – 76 mm (depending on lens and focus position) / IP 67 (NEMA 4)	45 x 45 x 60 – 76 mm (depending on lens and focus position) / IP 67 (NEMA 4)	46 x 45 x 60 – 75 mm (depending on lens and focus position) / IP 67 (NEMA 4)
Weight		195 g, incl. lens	215 g, incl. lens	195 g, incl. lens
Shock/ Vibration		IEC 60068-2-27 (25G and 50G) / IEC 60068-2-6 (sinus shaped), IEC 60068-2-64 (broadband noise)	IEC 60068-2-27 (25G and 50G) / IEC 60068-2-6 (sinus shaped), IEC 60068-2-64 (broadband noise)	IEC 60068-2-27 (25G and 50G) / IEC 60068-2-6 (sinus shaped), IEC 60068-2-64 (broadband noise)
Tripod mount		1/4-20 UNC	1/4-20 UNC	1/4-20 UNC
Power supply		via USB	via USB	via USB
Scope of supply (standard)		<ul style="list-style-type: none"> • USB camera with 1 lens • USB cable (1 m) • Table tripod • PIF cable with terminal block (1 m) • Manual • Software package optris® PIX Connect • Aluminum case 	<ul style="list-style-type: none"> • USB camera with 1 lens and BI-SPECTRAL technology • USB cable (1 m) • Table tripod • Focus tool • PIF cable with terminal block (1 m) • Manual • Software package optris® PIX Connect • Aluminum case 	<ul style="list-style-type: none"> • USB camera with 1 lens • USB cable (1 m) • Table tripod • PIF cable with terminal block (1 m) • Manual • Software package optris® PIX Connect • Aluminum case (PI 400i) • Robust hard shell case (PI 450i)

¹⁾ Accuracy effective starting at 150 °C

²⁾ For ideal combination of IR and VIS image, a 41° HFOV lens is recommended (PI 200). For the PI 230, a 23° lens is recommended.

³⁾ The additional measuring range is not available for 72° (PI 160 / 2xx), 80° (PI 4xx) and 90° (PI 640) lenses.

⁴⁾ Folgende Varianten können eingestellt werden:

 Variante 1 (IR with 96 Hz bei 160 x 120 px; VIS with 32 Hz bei 640 x 480 px)
 Variante 2 (IR with 128 Hz bei 160 x 120 px; VIS with 32 Hz bei 596 x 447 px)

optris® PI Infrared cameras

– The Precision Line

Compact infrared cameras for fast online applications – including line scanner



Basic model	PI 640	Microscope optics PI 640	PI 450 G7
Type	IR	IR	IR
Detector	FPA, uncooled (17 µm pitch)	FPA, uncooled (17 µm pitch)	FPA, uncooled (25 µm pitch)
Optical resolution	640 x 480 pixels VGA	640 x 480 pixels @ 32 Hz 640 x 120 pixels @ 125 Hz	382 x 288 pixels
Spectral range	8 – 14 µm	8 – 14 µm	7.9 µm
Temperature ranges	–20 ... 100 °C, 0 °C... 250 °C, (20) 150 ... 900 °C ¹⁾ , 200 ... 1500 °C (Option) ⁴⁾	–20 ... 100 °C 0 ... 250 °C (20) 150 ... 900 °C ¹⁾	150 ... 900 °C 200 ... 1500 °C
Frame rate	32 Hz / 125 Hz im Subframe mode (640x120 pixels)	32 Hz / 125 Hz in subframe mode (640 x 120 Pixel)	80 Hz / switchable to 27 Hz
Optics (FOV)	33° x 25° / f = 18.7 mm or 15° x 11° / f = 41.5 mm or 60° x 45° / f = 10.5 mm or 90° x 64° / f = 7.7 mm	12° x 9° (F=1.1) / f= 44 mm Smallest measuring spot: 28 µm	29° x 22° (f= 18.7 mm) 13° x 10° (f= 41 mm) 53° x 40° (f= 10.5 mm) 80° x 56° (f = 7.7 mm)
Thermal sensitivity (NETD)	75 mK	120 mK	130 mK
Accuracy	±2 °C or ±2 %, whichever is greater	±2 °C or ±2 %, whichever is greater	±2 °C or ±2 %, whichever is greater
PC interface	USB 2.0 / optional USB to GigE (PoE) interface	USB 2.0 / optional USB to GigE (PoE) interface	USB 2.0 / optional USB to GigE (PoE) interface
Process Interface (PIF)	Standard PIF 1x 0–10 V input, 1x digital input (max. 24 V), 1x 0–10 V output Industrial PIF (optional) 2x 0–10 V inputs, 1x digital input (max. 24 V), 3x 0–10 V outputs, 3x relays (0–30 V / 400 mA), 1x fail-safe relays	1x 0–10 V input, 1x digital input (max. 24 V), 1x 0–10 V output 2x 0–10 V inputs, 1x digital input (max. 24 V), 3x 0–10 V outputs, 3x relays (0–30 V / 400 mA), 1x fail-safe relays	1x 0–10 V input, 1x digital input (max. 24 V), 1x 0–10 V output 2x 0–10 V inputs, 1x digital input (max. 24 V), 3x 0–10 V outputs, 3x relays (0–30 V / 400 mA), 1x fail-safe relays
Ambient temperature (T _{Amb})	0 ... 50 °C	0 ... 50 °C	0 ... 70 °C
Storage temperature	–40 ... 70 °C	–40 ... 70 °C	–40 ... 85 °C
Relative humidity	20 – 80 %, non-condensing	20 – 80 %, non-condensing	20 – 80 %, non-condensing
Size / Class	46 x 56 x 76 – 100 mm (depending on lens and focus position)/ IP 67 (NEMA 4)	46 x 56 x 119 – 126 mm (depending on focus position)/ IP 67 (NEMA 4)	46 x 56 x 76 – 100 mm (depending on lens and focus position)/ IP 67 (NEMA 4)
Weight	320 g, incl. lens	370 g, incl. lens	320 g, incl. lens
Shock/ Vibration	IEC 60068-2-27 (25G and 50G) / IEC 60068-2-6 (sinus shaped), IEC 60068-2-64 (broadband noise)	IEC 60068-2-27 (25G and 50G) / IEC 60068-2-6 (sinus shaped), IEC 60068-2-64 (broadband noise)	IEC 60068-2-27 (25G and 50G) / IEC 60068-2-6 (sinus shaped), IEC 60068-2-64 (broadband noise)
Tripod	1/4 - 20 UNC	1/4 - 20 UNC	1/4 - 20 UNC
Power supply	via USB	via USB	via USB
Scope of supply (standard)	<ul style="list-style-type: none"> • USB camera with 1 lens • USB cable (1 m) • Table tripod • PIF cable with terminal block (1 m) • Manual • Software package optris® PIX Connect • Robust hard shell case 	<ul style="list-style-type: none"> • USB camera • Standard lens (O33) • Mikroskope lens (MO44) • Mikroskope stand • Standard USB cable (1 m) • PIF cable with terminal block (1 m) • Manual • Software package optris® PIX Connect • Robust hard shell case 	<ul style="list-style-type: none"> • USB camera with 1 lens • USB cable (1 m) • Table tripod • PIF cable with terminal block (1 m) • Manual • Software package optris® PIX Connect • Robust hard shell case

Optics calculator: www.optris.global/optics-calculator



PI 640 G7	PI 05M	PI 08M	PI 1M
IR	IR	IR	IR
FPA, uncooled (17 μm pitch)	CMOS (15 μm pitch)	CMOS (15 μm pitch)	CMOS (15 μm pitch)
640 x 480 pixels	764 x 480 pixels @ 32 Hz 382 x 288 pixels @ 80 Hz (switchable to 27 Hz) 72 x 56 pixels @ 1 kHz 764 x 8 pixels @ 1 kHz (fast line-scan mode)	764 x 480 pixels @ 32 Hz 382 x 288 pixels @ 80 Hz (switchable to 27 Hz) 72 x 56 pixels @ 1 kHz 764 x 8 pixels @ 1 kHz (fast line-scan mode)	764 x 480 pixels @ 32 Hz 382 x 288 pixels @ 80 Hz (switchable to 27 Hz) 72 x 56 pixels @ 1 kHz 764 x 8 pixels @ 1 kHz (fast line-scan mode)
7.9 μm	500 – 540 nm	780 – 820 nm	0.85 – 1.1 μm
150 ... 900 °C 200 ... 1500 °C	900 ... 2450 °C (27 Hz mode) 950 ... 2450 °C (32/80 Hz mode) 1100 ... 2450 °C (1 kHz mode)	575 °C ... 1900 °C (27 Hz mode) 625 °C ... 1900 °C (32 / 80 Hz mode) 750 °C ... 1900 °C (1 kHz mode)	450 ⁵⁾ ... 1800 °C (27 Hz mode) 500 ⁵⁾ ... 1800 °C (80 Hz- and 32 Hz mode) 600 ⁵⁾ ... 1800 °C (1 kHz mode)
32 Hz / 125 Hz in subframe mode (640x120 Pixel)	Up to 1 kHz / 1 ms real time analog output (0 - 10 V) von 8 x 8 pixels (freely selectable)	Up to 1 kHz / 1 ms real time analog output (0 - 10 V) von 8 x 8 pixels (freely selectable)	Up to 1 kHz / 1 ms real time analog output (0 - 10 V) von 8 x 8 pixels (freely selectable)
33° x 25° (f = 18.7 mm) 15° x 11° (f = 42 mm) 60° x 45° (f = 10.5 mm) 90° x 64° (f = 7.7 mm)	FOV @ 764 x 480 px: 26° x 16° (f = 25 mm)	FOV @ 382 x 288 px: 13° x 10° (f = 25 mm)	FOV @ 764 x 480 px: 39° x 25° (f = 16 mm) 26° x 16° (f = 25 mm) 13° x 8° (f = 50 mm) 9° x 5° (f = 75 mm)
130 mK	< 2 K (1400 °C) for 27 Hz, 32 Hz, 80 Hz < 2.5 K (1400 °C) for 1 kHz	< 2 K (<1000 °C/ 27 Hz to 1kHz) < 4 K (>1000 °C/ 27 Hz to 1 kHz)	< 1 K (700 °C) < 2 K (1000 °C)
±2 °C or ±2 %, whichever is greater	±1.5 % of reading	±1 % of reading (<1500 °C) +/- 1.5 % of reading (>1500 °C) ⁷⁾	±1 % of reading (object temp. <1400 °C)
USB 2.0 / optional USB to GigE (PoE) interface	USB 2.0 / optional USB to GigE (PoE) interface	USB 2.0 / optional USB to GigE (PoE) conversion	USB 2.0 / optional USB to GigE (PoE) interface
1x 0–10 V input, 1x digital input (max. 24 V), 1x 0–10 V output	1x 0–10 V input, 1x digital input (max. 24 V), 1x 0–10 V output	1x 0–10 V input, 1x digital input (max. 24 V), 1x 0–10 V output	1x 0–10 V input, 1x digital input (max. 24 V), 1x 0–10 V output
2x 0–10 V inputs, 1x digital input (max. 24 V), 3x 0–10 V outputs, 3x relays (0–30 V / 400 mA), 1x fail-safe relays	2x 0–10 V inputs, 1x digital input (max. 24 V), 3x 0–10 V outputs, 3x relays (0–30 V / 400 mA), 1x fail-safe relays	2x 0–10 V inputs, 1x digital input (max. 24 V), 3x 0/4 – 20 mA outputs, 3x relays (0–30 V / 400 mA), 1x fail-safe relays	2x 0–10 V inputs, 1x digital input (max. 24 V), 3x 0–10 V outputs, 3x relays (0–30 V / 400 mA), 1x fail-safe relays
0...50 °C	5 ... 50 °C	5 ... 50 °C	5 ... 50 °C
–40 ... 70 °C	– 40 ... 70 °C	– 40 ... 70 °C	– 40 ... 70 °C
20–80 %, non-condensing	20–80 %, non-condensing	20–80 %, non-condensing	20–80 %, non-condensing
46 x 56 x 76 – 100 mm (depending on lens and focus position) / IP 67 (NEMA 4)	46 x 56 x 88 – 129 mm with protection tube (depending on lens and focus position) / IP 67 (NEMA 4) ⁶⁾	46 x 56 x 88 – 129 mm with protection tube (depending on lens and focus position) / IP 67 (NEMA 4) ⁶⁾	46 x 56 x 88 – 129 mm with protection tube (depending on lens and focus position) / IP 67 (NEMA 4) ⁶⁾
320 g, incl. lens	320 g, incl. lens	320 g, incl. lens	320 g, incl. lens
IEC 60068-2-27 (25G and 50G) / IEC 60068-2-6 (sinus shaped), IEC 60068-2-64 (broadband noise)	IEC 60068-2-27 (25G and 50G) / IEC 60068-2-6 (sinus shaped), IEC 60068-2-64 (broadband noise)	IEC 60068-2-27 (25G and 50G) / IEC 60068-2-6 (sinus shaped), IEC 60068-2-64 (broadband noise)	IEC 60068-2-27 (25G and 50G) / IEC 60068-2-6 (sinus shaped), IEC 60068-2-64 (broadband noise)
1/4 - 20 UNC	1/4 - 20 UNC	1/4 - 20 UNC	1/4 - 20 UNC
via USB	via USB	via USB	via USB
<ul style="list-style-type: none"> • USB camera with 1 lens • USB cable (1 m) • Table tripod • PIF cable with terminal block (1 m) • Manual • Software package optris® PIX Connect • Robust hard shell case 	<ul style="list-style-type: none"> • USB camera with 1 lens • Lens protection tube incl. protective window • USB cable (1 m) • Table tripod • PIF cable with terminal block (1 m) • Manual • Software package optris® PIX Connect • Aluminum case • Optional: CoolingJacket, HT cable 	<ul style="list-style-type: none"> • USB camera with 1 lens • Lens protection tube incl. protective window • USB cable (1 m) • Table tripod • PIF cable with terminal block (1 m) • Manual • Software package optris® PIX Connect • Aluminum case • Optional: CoolingJacket, HT cable 	<ul style="list-style-type: none"> • USB camera with 1 lens • Lens protection tube incl. protective window • USB cable (1 m) • Table tripod • PIF cable with terminal block (1 m) • Manual • Software package optris® PIX Connect • Aluminum case • Optional: CoolingJacket, HT cable

⁵⁾ +75 °C higher starting temperature when using optics ⁷⁾ for 1 kHz mode: +/- 1.5 % of reading (<1500 °C) / +/- 2 % of reading (>1500 °C)

with focal length f=50 mm and f=75 mm

⁶⁾ Only applies when using the lens protection tube

optris® PI NETBOX

MINI PC FOR OPTRIS® PI SERIES

Stand alone solution for optris® PI series

- Miniatur PC as an add-on to the PI series for stand-alone system of for cable extension via GigE
- Integrated hardware and software watchdog
- Installation of additional user software possible
- Status LEDs
- Processor: Intel® E3845 Quad Core / 1.91 GHz, 16 GB SSD, 2 GB RAM
- Connections: 2x USB 2.0, 1x USB 3.0, 1x Mini USB 2.0, Micro HDMI, Ethernet (Gigabit Ethernet), Micro SDHC / SDXC card
- Operating system: Windows 7 Professional
- Wide supply voltage range (8 – 48 V DC) or Power over Ethernet (PoE)
- Can be integrated with CoolingJacket Advanced



General specifications

Ambient temperature	0 °C... 50 °C
Storage temperature	-20 °C... 75 °C
Relative Humidity	10-95 %, non-condensing
Material (Housing)	Anodized aluminum
Size	113 x 57 x 47 mm
Weight	385 g
Vibration	IEC 60068-2-6 (sinusoidal) / IEC 60068-2-64 (broadband noise)
Shock	IEC 60068-2-27 (25 G and 50 G)
Operating system	Windows 7 Professional

Electrical specifications

Voltage supply	8-48 V DC or Power over Ethernet (PoE/ 1000BASE-T)
Power consumption	7.5 W (+ additional 2.5 W for PI camera)
Cooling	Active via two integrated fans
Module	COM Express® mini embedded board
Processor	Intel® E3845 Quad Core, 1.91 GHz
Hard drive	16 GB SSD
RAM	2 GB (DDR2, 533 MHz)
Connections	2x USB 2.0, 1x USB 3.0, 1x Mini-USB 2.0, Micro-HDMI, Ethernet (Gigabit Ethernet)
Memory card slots	Micro SDHC/ SDXC card
Additional features	4x Status-LEDs

Stand-alone solution with GigE remote access

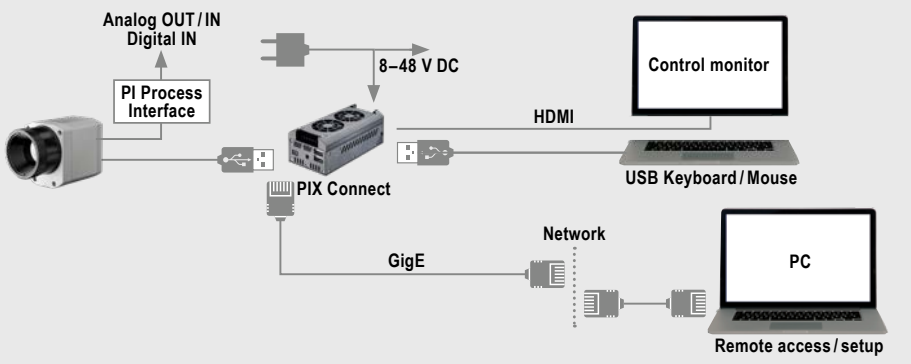

Simple cable extension for the optris® PI series and optris® Xi 400

- Fully compatible with USB 2.0, Data transfer rate 1.5 / 12 / 480 Mbps, USB transfer mode: isochronous
- Network connection via Gigabit Ethernet
- For all models in the optris® PI series and the Xi 400
- Full TCP/IP support incl. routing and DNS
- Two independent USB connections
- Power via PoE or external voltage supply at 24 – 48 V DC
- Galvanic isolation 500 VRMS (network connection)
- Remote configuration via web-based management
- Certified technology from Wiesemann & Theis



Technical data

USB connections	2 x USB A Port
USB speed	480 Mbps
Network	10/100/1000 BaseT (max. 1000 Mbps)
Power supply	Power over Ethernet (PoE) class 3 (6,49 – 12,95 W) or via screw terminal DC 24 V ... 48 V (+/-10 %)
Power consumption	External power supply (24 V DC) without USB devices: typ. 120 mA External power supply (24 V DC) with 2 USB devices each 2.5 W: typ. 420 mA
Ambient temperature	Storage: -40 ... 85 °C In operation, individually assembled: 0 ... 50 °C
Permissible relative humidity	0 – 95 % (non-condensing)
Housing	Compact plastic casing for DIN rail mount, 105 x 75 x 22 mm
Weight	200 g
Scope of supply	<ul style="list-style-type: none"> • 1x USB server Gigabit 2.0 • 24 V DC wall plug transformer • Quick start guide* * included on PIX Connect-CD or Compact Connect-CD – USB-Redirector – WuTility Management Tool – Manual (DE / EN)

Protocols

USB protocols	USB 1.0 / 1.1 / 2.0 Control / Bulk / Interrupt / Isochronous
Protocols for direct network connection	TCP/IP: Socket Auxiliary protocols: ARP, DHCP, HTTP, PING Inventory keeping, group management

Connection options

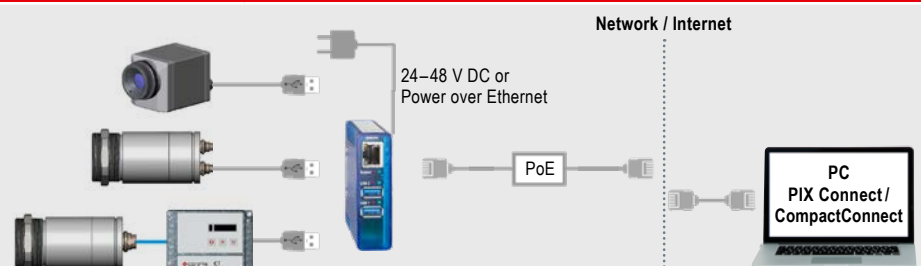

optris® CoolingJacket

UNIVERSAL PROTECTIVE HOUSING
FOR COOLING UP TO 315 °C

Universal protection for the optris® PI series in harsh industrial environments

- Operation at ambient temperatures of up to 315 °C
- Air/Water cooling with integrated air purging and optional protective windows
- Modular design for easy fitting of different devices and lenses
- Trouble-free, on the spot sensor removal via quick-release chassis
- Integration of additional components like PI NetBox, USB Server Gigabit and Industrial Process Interface (PIF) in the extended version



Technical data	CoolingJacket	CoolingJacket Advanced Standard	CoolingJacket Advanced Extended
Protective rating	IP 52	IP 65	IP 65
Ambient temperature	Up to 180 °C	Up to 315 °C ¹⁾	Up to 315 °C ¹⁾
Relative Humidity	10 - 95 %, non-condensing	10 - 95 %, non-condensing	10 - 95 %, non-condensing
Material (Housing)	V2A	V2A	V2A
Dimensions	237 x 117 x 138 mm	271 x 166 x 182 mm	426 x 166 x 182 mm
Weight	4.5 kg	5.7 kg	7.8 kg
Air purge collar	G1/4" internal thread G3/8" external thread	G1/4" internal thread G3/8" external thread	G1/4" internal thread G3/8" external thread
Cooling water fittings	G1/4" internal thread G3/8" external thread	G1/4" internal thread G3/8" external thread	G1/4" internal thread G3/8" external thread
Cooling water pressure	max. 15 bar (217 psi)	max. 15 bar (217 psi)	max. 15 bar (217 psi)
Scope of supply	<ul style="list-style-type: none"> • CoolingJacket, consisting of housing and chassis 	<ul style="list-style-type: none"> • CoolingJacket Advanced, consisting of housing with mounting brackets, chassis and focusing unit respectively front part²⁾ • Installation instructions 	<ul style="list-style-type: none"> • CoolingJacket Advanced, consisting of housing with mounting brackets, chassis and focusing unit respectively front part²⁾ • Mounting accessories for – PI Netbox or USB-Server Gigabit 2.0 – Industrial PIF • Installation instruction

¹⁾ Cable for up to 250 °C ambient temperature as well as cable cooling for up to 315 °C available.

²⁾ Focusing unit and front part are exchangeable and have to be ordered separately. Instructions

Dimensions in mm

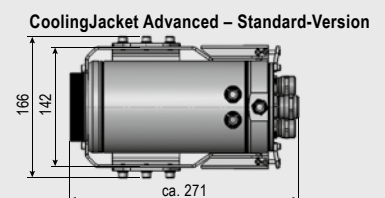
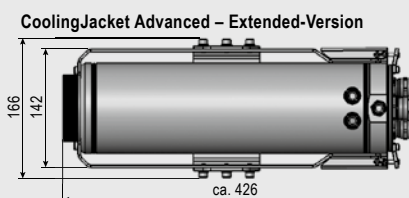
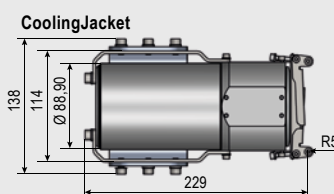

optris® LAMINAR AIR PURGE

AIR PURGE FOR RUGGED ENVIRONMENTS

innovative infrared technology

Laminar air purge for rugged environments

- Protection for rugged environments
- Air and water cooling, flexible laminar air stream for protection from dirt and dust
- Easy maintenance due to folding mechanism
- Focussable from the outside once installed
- Protection window for mechanical protection integrated
- Also available as line scanner version

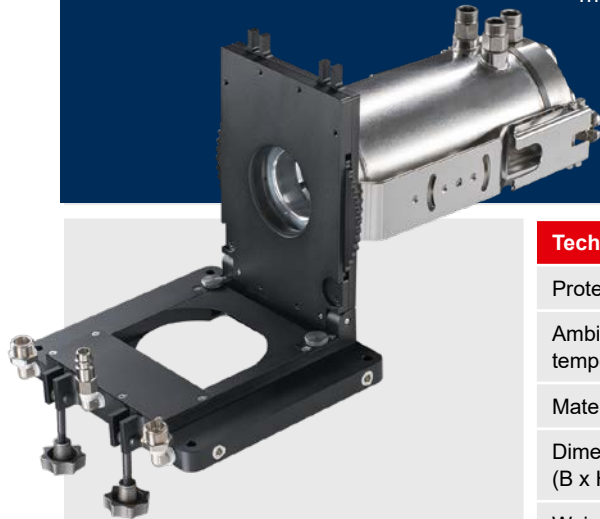

Technical data

Protective rating	IP 65
Ambient temperature	Up to 315 °C (with water cooling)
Material	Aluminum
Dimensions (B x H x T)	200 x 189 x 43 mm
Weight	1.9 kg
Air purge connection	NW 7.2
Cooling water connection	G3/8" external thread
Cooling water pressure	Max. 8 bar
Volume flow	120 l/min
Air pressure	1.1 - 8 bar
Protective window	Necessary ¹⁾
Version/Options	Also available as line scan option

¹⁾ A protective window (67 x 3 mm) has to be ordered separately.

Dimensions in mm

Laminar air purge: standard model

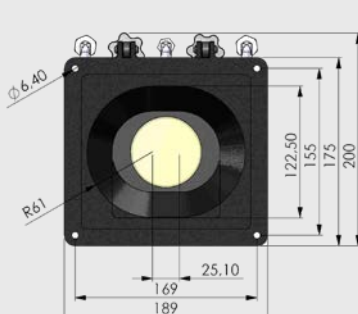

Laminar air purge: line scan model

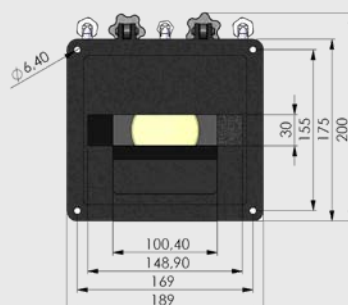

Laminar air purge: connections

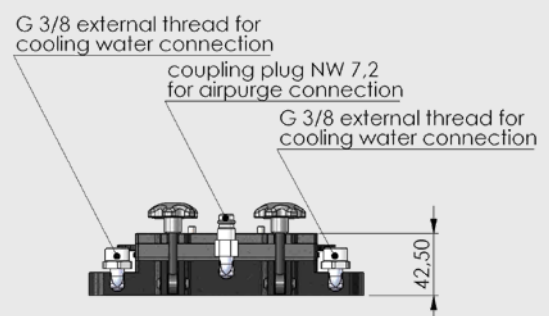

optris® Industrial Process Interface

WITH FAIL-SAFE MONITORING

Camera and process control for use in industrial environment

- Industrial Process Interface for PI series and Xi 400 with 3 analog-/ alarm outputs, 2 analog inputs, 1 digital input, 3 alarm relays
- Industrial Process Interface for Xi 80 with 3 analog-/alarm outputs, 3 inputs (analog or digital), 3 alarm relays
- 500 V AC_{RMS} isolation voltage between camera and process
- Separate fail-safe relay output
- The PI / Xi hardware with all cable connections and the PIX Connect software are permanently monitored during operation
- Combination of up to 3 PIFs when using the Xi 80



General specifications

Protective rating	IP65 (NEMA-4)
Ambient temperature	-30 °C ... 85 °C
Storage temperature	-30 °C ... 85 °C
Humidity	10–95 %
Vibrational stability	IEC 60068-2-6 (non-condensing)/ IEC 60068-2-64 (broadband noise)
Shock stability	IEC 60068-2-27 (25 G and 50 G)
Weight	610 g (with 5 m HT cable)
Cable lengths	5 m HT cable (standard), optional 10 m and 20 m

Electrical specifications

	Xi 80	PI series and Xi 400
Power supply	5–24 V DC	5–24 V DC
LED display	2 green LEDs for voltage and fail-safe / 3 red LEDs for status of alarm relays	2 green LEDs for voltage and fail-safe / 3 red LEDs for status of alarm relays
Isolation	500 V AC _{RMS} between camera and process	500 V AC _{RMS} between camera and process
Outputs	3 analog-/ alarm outputs / 3 alarm relays	3 analog-/ alarm outputs / 3 alarm relays ¹
Inputs	3 inputs (analog or digital)	2 analog inputs / 1 digital input
Ranges	0/4–20 mA or 0–10 V (for AO 1–3) ² , 0–10 V or 24 V (for inputs 1–3), 0–30 V/400 mA (for alarm relays DO 1–3)	0/4–20 mA (for AO 1–3) ² , 0–30 V / 400 mA (for alarm relays DO1–3) / 0–10 V (for AI 1–2) / 24 V (for DI)

Programmable functions

Analog inputs	<ul style="list-style-type: none"> • Emissivity settings • Reference temperature • Triggered snapshots, triggered recordings, triggered line scan camera, triggered event grabber 	<ul style="list-style-type: none"> • Ambient temperature compensation • Uncommitted value • Flag control • Reset peak-/valley hold
Digital inputs	<ul style="list-style-type: none"> • Flag control • Triggered snapshots, triggered recordings, triggered line scan camera, triggered event grabber 	<ul style="list-style-type: none"> • Reset peak-/valley hold
Analog outputs	<ul style="list-style-type: none"> • Main measurement range • Measurement range • Internal temperature • Flag status 	<ul style="list-style-type: none"> • Alarm • Frame synchronisation • Fail-safe • External communication

¹) Active when AO1, 2 or 3 is / are programmed as alarm output

²) Dependent on supply voltage

optris® Outdoor Protective Housing

innovative infrared technology

UNIVERSAL PROTECTIVE HOUSING FOR IR CAMERAS

Universal outdoor protection for infrared cameras of the optris® PI and Xi series

- Environmental rating IP 66
- Additional air purge collar allows for a continuous operation in dusty and humid conditions
- Heating element and built-in fan enable for a 24/7 operation from -40 °C to 50 °C
- Optional Installation of USB Server Gigabit for integration into control systems over large outdoor distances



Specifications

Environmental rating	IP 66
Ambient temperature	-40 ... 50 °C
Heating	PTC heater (automatically starting at T < 15 °C) / fan for homogeneous temperature distribution
Power supply	24 V DC
Power	70 W
Protective window	Germanium (Ge), zinc sulfide (ZnS), Borofloat or foil
Air purge collar	Integrated
Integrable additional components	USB Server Gigabit 2.0 Industrielles Prozess Interface (PIF)
Max. FOV	90° (HFOV)
Accessories	Optional wall mount bracket

Example of fail-safe monitoring of the PI camera with connected PLC

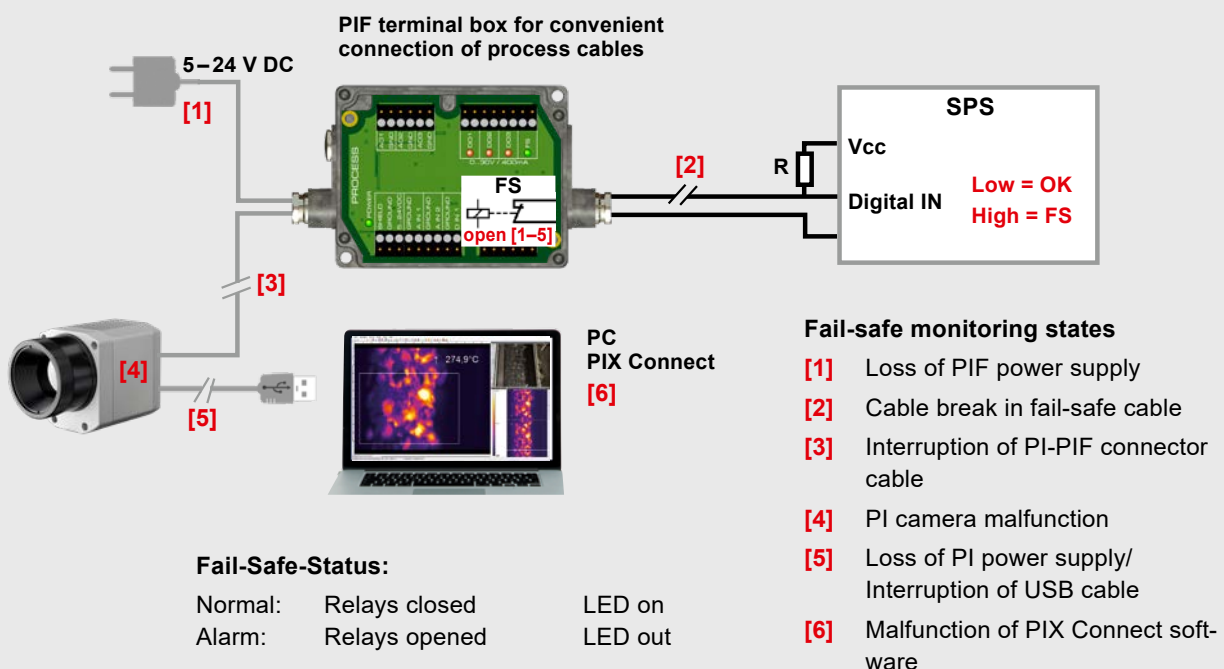

Comprehensive IR camera software

- No additional costs or licensing restrictions
- Modern software with intuitive user interface
- Remote control of camera
- Display of numerous images in different windows
- Compatible with Windows 7, 8 and 10
- Two Software Development Kits for Windows and Linux included
- Various language options, incl. translation function
- Temperature display in °C or in °F

Real-time temperature information in main window, as digital display or as graphic

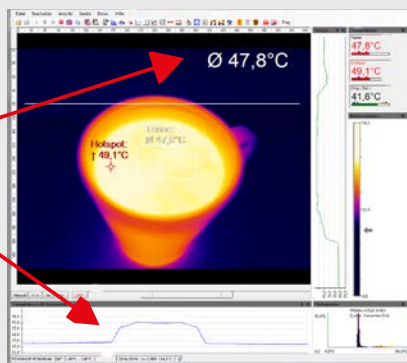

**Our layouts – as individual
as your applications**

Pre-defined layouts make it quick and easy to start with your applications. And because we know that every measurement task has its own individual requirements, we have ensured that it is quite easy to adapt the preset layout to suit your individual requirements.

The user interface of the PIX Connect software can also be adapted to suit your personal workflow: Software windows can be easily arranged using drag & drop; in the toolbar you can save shortcuts for functions relevant to your application – or even remove links which you do not need.

Regardless of whether you are working on a desktop PC or a tablet, the user interface can be adapted.

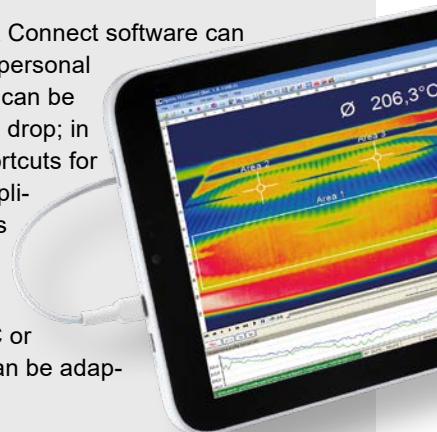

The PIX Connect software makes a wide range of preset color palettes available. This allows optimal depiction of thermal contrasts. The pre-defined color palettes can be individually adapted to be able to cater for the specific requirements of your respective application.

Associated temperature groups (isotherms) can be identified by color markers and highlighted. It is also possible to define temperature values in advance; pixels above, below, or between these values are highlighted in color.

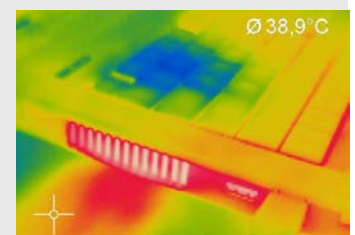
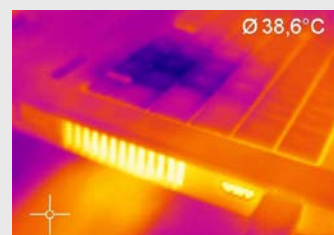

**The right color palette for
every application**

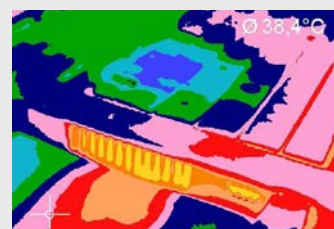
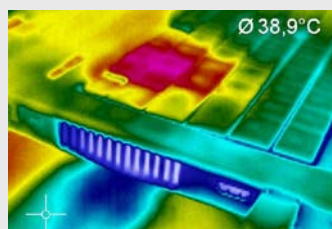
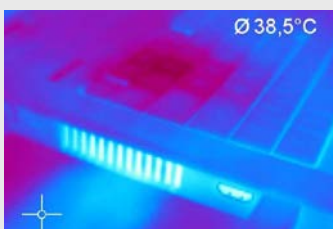

Measuring areas

It is not just a matter of size, but also depends on the content: designing a suitable measurement area

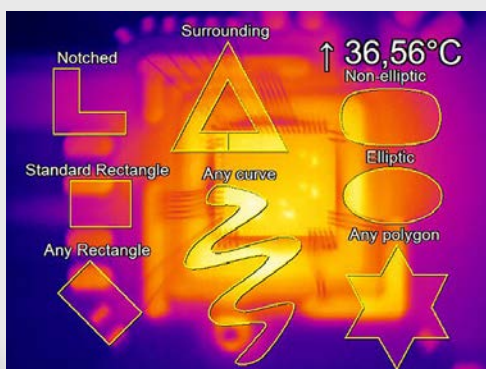

The size and shape of measurement area can be freely designed and moved. For an easy introduction, a large selection of pre-defined measurement area shapes is available.

You can set up as many measurement areas as you like in the camera's field of view. To do this, it is possible to make a distinction between main and ancillary fields.

Various modes can be set in a measurement area, such as minimum value, maximum value, or average value, or you can rule out the detection of hot or cold spots.

The separate setting of the emissivity for measurement areas allows various material surfaces to be monitored with a single camera.

Differences and averaging between different measurement areas are easy to calculate with the PIX Connect software.

Saved measurement areas can be displayed as an image, a digital display or a diagram and can then be saved for further analysis.

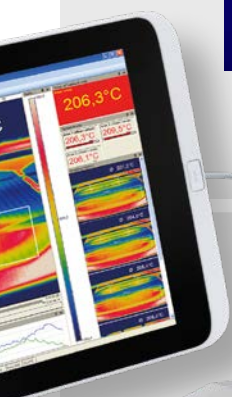

Graphic display of the temperature values

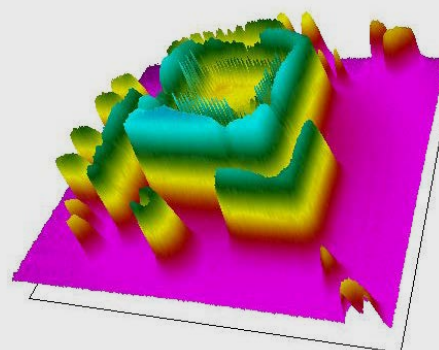

Temperature values can be shown along a straight line as temperature profiles as well as as 3D diagrams.

A temperature/time diagram can be used to analyze the temperature development over time. Individual time sections can be lifted out of the diagram and be analyzed in detail by zooming in and out.

Diagrams defined in this way can be exported from the software and be saved in Excel for further analysis.

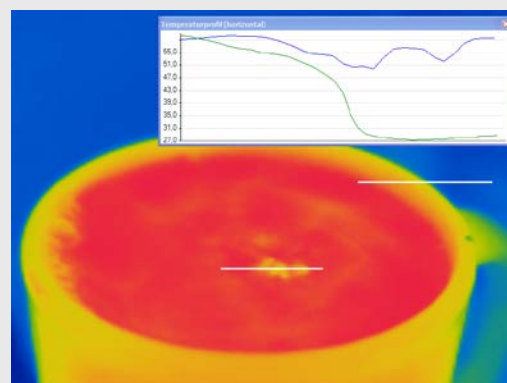

Recording and display

Recording video sequences for later analysis and documentation

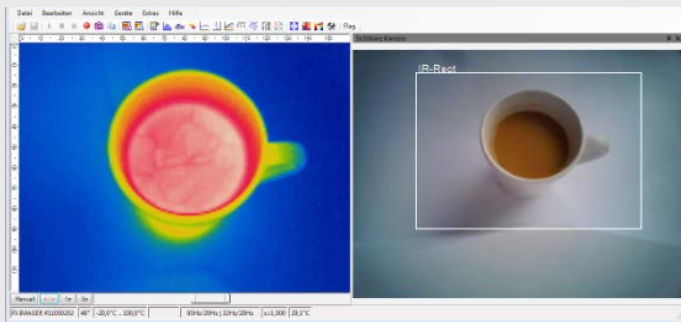

The software can be used to save the recording from the thermal imaging camera as video sequences which can then be saved for analysis later on. The video sequence is recorded for every pixel including all temperature information. An integrated screen capture function makes it simple to retrospectively generate videos in wmv format.

BI-SPECTRAL video analysis where both an IR as well as a VIS image are recorded makes it easy to highlight critical temperature ranges.

Videos recorded can be processed retrospectively. For example, individual sections can be cut out of a recording and can be saved as an independent sequence.

Saved video recordings are available for analysis. The sequences can be played back in slow motion or time lapse for this purpose. It is also possible to play back as a continuous loop.

The snapshot option works like a screenshot; an individual image is recorded from the live picture. This snapshot is a radiometric image (*.tiff), where all the temperature and measurement area information at the time of the recording is saved for every pixel.

Saving and exporting the image for further analysis in Excel is possible thanks to the option of saving the temperature matrix in text format, e.g. as comma-separated values (.csv format). It is also possible to continue processing the image data with standard programs such as Photoshop or Windows Media Player.

Sections of the saved image can be zoomed in to get a closer look. 3D display is also possible.

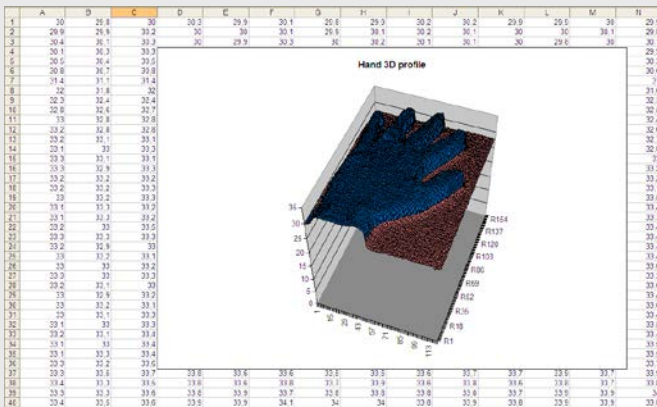

Snapshots – all temperature information in one picture

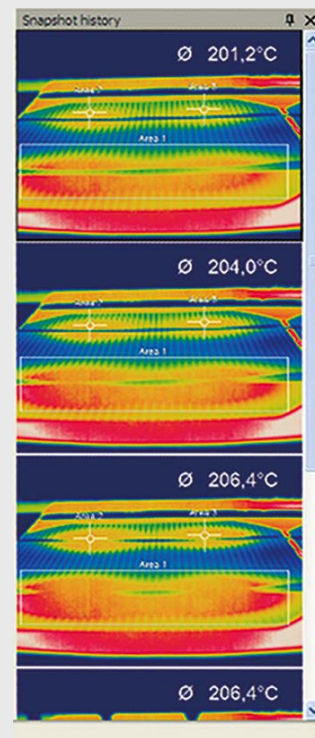

Merging

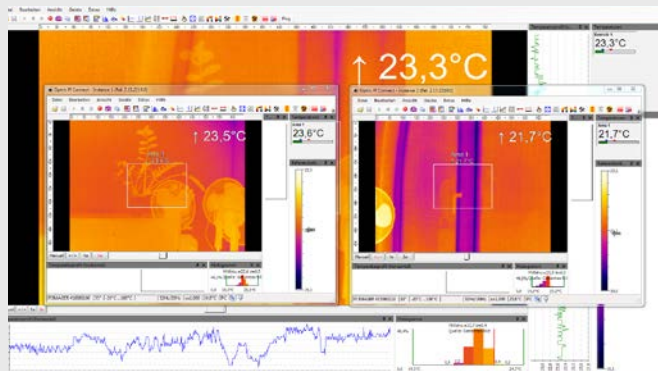

The fields of vision of three cameras (top) are converted into one single image via the merging function (right)

The merging function combines several camera angles together in a single picture



The PIX Connect software gives you the option of grouping together several cameras within a software instance, i.e. the field of view of several infrared cameras are merged together to make a single picture. For processes with several control points in particular, it is helpful to concentrate the various angles on one screen. Merging several cameras also makes it possible to get an all-round view of a 3D object.

You can merge several cameras either using a direct USB connection or via Ethernet. While in the first case, every camera needs to have its own USB port; for the second option, one Ethernet connection is enough. The cameras here are each connected to the Ethernet switch on the PC via a USB Server Gigabit 2.0.

Alarms

Temperature dependent alarms for freely definable measurement areas as well as the internal temperature of the camera can be chosen via the software. Apart from minimum and maximum values, it is also possible to set so-called advance alarms. These will emit a warning when the measured temperature approaches the defined minimum or maximum value, therefore giving you more options and time to react.

If the measured temperature reaches one of these previously defined values, then the software will trigger an alarm. In addition to that, the critical event can be easily documented as a snapshot or video recording and be used for analysis later on.

Defining several alarm values allows quick intervention

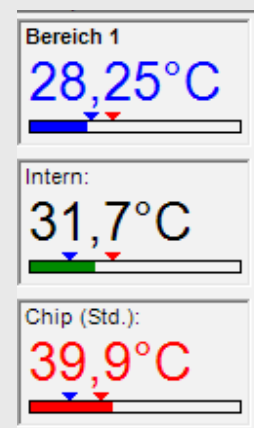

For the measurement of moving objects

The optris® PIX Connect software is equipped with a line scan camera function. The line scanner is primarily used for processes involving moving measurement objects, like rotary kiln measurements or large quantities on conveyor belts (batch process).



The advantages

Simple monitoring of processes with limited visual access

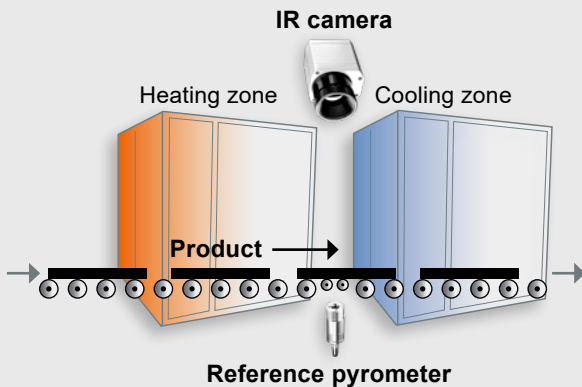

Indirect visualization of heat distribution in ovens via camera installation at oven exit

Only 3 steps to initialize the function

Step 1

Activation of the line scan camera function (continuous, self-triggered, external trigger) and definition of the position of the lines in the thermal image. For this the camera itself serves as an orientation aid.

Step 2

Configuration of line scan function, e.g. number of lines displayed or set trigger for automatic saving of images.

Step 3

Definition of individual layouts, e.g. display of saved images in the snapshot process.

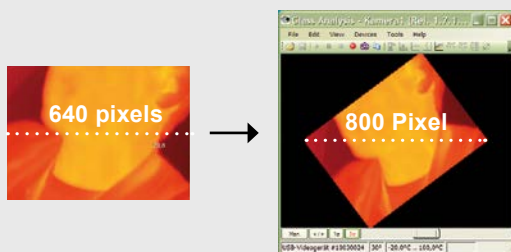

Increase in the number of pixels, e.g. from 640 pixels to 800 pixels by using diagonal screen measurement

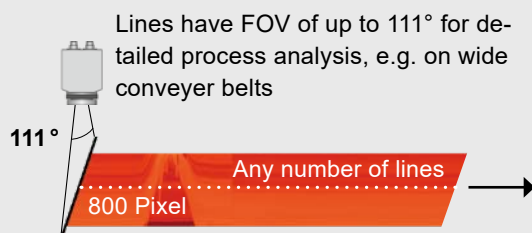

Up to 32 Hz data recording* of unlimited lines which in turn produce a thermal image of any given resolution.

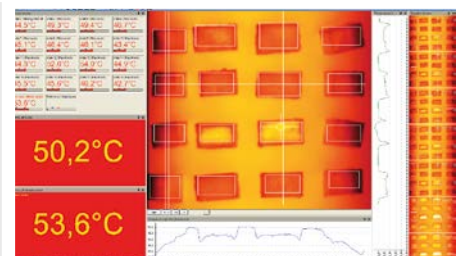

Layout example for display of line scan camera function

*Up to 125 Hz data recording when using 90° in subframe mode (640 x 120)

Precise measuring at various distances

A choice of lenses allows you to precisely measure objects at various distances, from close and standard distances right up to large distances. The IR cameras of the optris® PI series allow for changing between several lenses.

With infrared cameras there are various parameters which display the relationship between the distance from the measuring object and the size of the pixel on the object plane. In choosing the correct lens, the following should be taken into account:

HFOV

Horizontal expansion of the total measuring field on the object plane

VFOV

Vertical expansion of the total measuring field on the object plane

IFOV

Size of individual pixels on the object plane

DFOV

Diagonal expansion of the total measuring field on the object plane

MFOV

Recommended, smallest measuring object size of 3 x 3 pixels or 2 x 2 pixels when using the PI microscope optics or the Xi 80, respectively

Measuring field of optris® PI infrared camera using a 23° x 17° lens

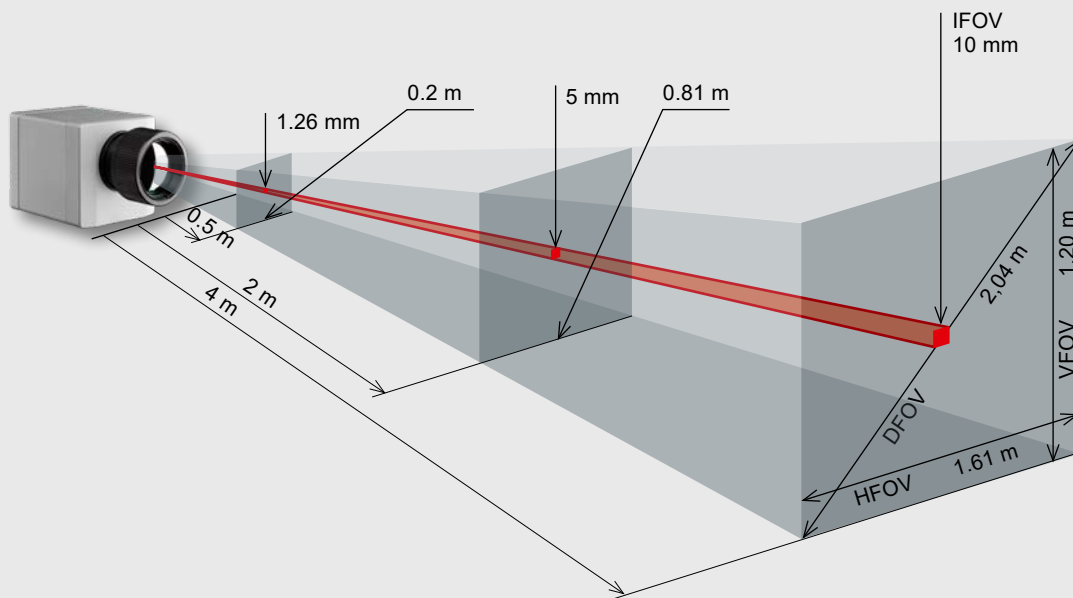

Optics calculator

Measurement field sizes for any given distance can be calculated online at

www.optris.global/optics-calculator



Optical data

OPTICS

Xi 80		Focal length [mm]	Minimum measurement distance*	Angle	Distance to measurement object [m]											
80 x 80 px					0.05	0.1	0.2	0.3	0.5	1	2	4	6	10	30	100
F05 Standard lens	5	0,2 m	30°	HFOV [m]	0.028	0.056	0.111	0.167	0.279	0.557	1.115	2.230	3.346	5.6	16.7	55.8
			30°	VFOV [m]	0.028	0.056	0.111	0.167	0.279	0.557	1.115	2.230	3.346	5.6	16.7	55.8
			43°	DFOV [m]	0.039	0.079	0.158	0.24	0.39	0.79	1.58	3.15	4.7	7.9	23.7	78.9
			6.67 mrad	I FOV [mm]	0.33	0.67	1.33	2.0	3.33	6.67	13.33	26.67	40.00	66.67	200.00	666.67
F13 Telephoto lens	13	0,3 m	12°	HFOV [m]		0.022	0.043	0.065	0.11	0.21	0.43	0.85	1.28	2.1	6.4	21.3
			12°	VFOV [m]		0.022	0.043	0.065	0.11	0.21	0.43	0.85	1.28	2.1	6.4	21.3
			17°	DFOV [m]		0.031	0.061	0.092	0.15	0.30	0.60	1.20	1.81	3.0	9.0	30.1
			2.66 mrad	I FOV [mm]		0.3	0.5	0.8	1.3	2.7	5.3	10.6	15.9	26.6	79.7	265.6
F03 Wide angle lens	3	0,2 m	55°	HFOV [m]	0.057	0.110	0.218	0.325	0.539	1.07	2.14	4.27	6.41	10.7	32.0	106.7
			55°	VFOV [m]	0.057	0.110	0.218	0.325	0.539	1.07	2.14	4.27	6.41	10.7	32.0	106.7
			79°	DFOV [m]	0.080	0.156	0.308	0.459	0.762	1.52	3.02	6.04	9.06	15.1	45.3	150.9
			11.15 mrad	I FOV [mm]	0.6	1.2	2.3	3.4	5.6	11.2	22.4	44.6	66.9	111.5	334.5	1114.8
F02 Wide angle lens	2	0,2 m	80°	HFOV [m]	0.090	0.174	0.343	0.509	0.884	1.682	3.357	6.708	10.058	16.8	50.3	167.5
			80°	VFOV [m]	0.090	0.174	0.343	0.509	0.88	1.682	3.357	6.708	10.058	16.8	50.3	167.5
			113°	DFOV [m]	0.127	0.246	0.483	0.72	1.19	2.38	4.75	9.49	14.2	23.7	71.1	236.9
			15.45 mrad	I FOV [mm]	0.08	1.6	3.2	4.7	7.8	15.5	31.0	61.9	92.8	154.6	463.7	1545.5

Xi 400		Focal length [mm]	Minimum measurement distance*	Angle	Distance to measurement object [m]											
382 x 288 px					0.05	0.1	0.2	0.3	0.5	1	2	4	6	10	30	100
F12 Standard lens	13	0.35 m	29°	HFOV [m]		0.055	0.111	0.16	0.27	0.52	1.04	2.1	3.1	5.2	15.5	51.7
			22°	VFOV [m]		0.042	0.081	0.12	0.20	0.39	0.78	1.6	2.3	3.9	11.7	38.9
			37°	DFOV [m]		0.069	0.137	0.20	0.33	0.66	1.30	2.6	3.9	6.5	19.4	64.7
			1.3 mrad	I FOV [mm]		0.1	0.3	0.4	0.7	1.3	2.7	5.4	8.0	13.4	40.2	133.9
F20 Telephoto lens	20	0.35 m	18°	HFOV [m]			0.067	0.099	0.16	0.32	0.65	1.29	1.9	3.2	9.7	32.2
			14°	VFOV [m]			0.051	0.076	0.12	0.25	0.49	0.98	1.5	2.5	7.4	24.6
			23°	DFOV [m]			0.084	0.125	0.21	0.41	0.81	1.62	2.4	4.1	12.2	40.5
			0.9 mrad	I FOV [mm]			0.2	0.3	0.4	0.9	1.7	3.4	5.1	8.5	25.6	85.4
F08 Wide angle lens	8	0.25 m	53°	HFOV [m]		0.105	0.20	0.30	0.50	1.00	2.00	4.00	6.0	10.0	29.9	99.7
			38°	VFOV [m]		0.073	0.14	0.21	0.35	0.70	1.4	2.8	4.1	6.9	20.7	68.9
			66°	DFOV [m]		0.128	0.25	0.37	0.62	1.22	2.4	4.9	7.30	12.1	36.4	121.2
			2.2 mrad	I FOV [mm]		0.22	0.4	0.7	1.1	2.2	4.4	8.8	13.2	22.0	65.9	219.6
F06 Super wide angle lens	6	0.2 m	80°	HFOV [m]	0.085	0.16	0.32	0.48	0.82	1.7	3.4	6.7	10.1	16.8	50.4	167.8
			54°	VFOV [m]	0.055	0.10	0.20	0.30	0.51	1.0	2.0	4.1	6.1	10.2	30.6	101.9
			96°	DFOV [m]	0.101	0.19	0.38	0.57	0.97	1.9	3.9	7.9	11.8	19.7	58.9	196.4
			3.0 mrad	I FOV [mm]	0.2	0.3	0.6	0.9	1.5	3.0	6.0	12.0	18.1	30.1	90.3	301.2

Table with examples showing which measurement field sizes and pixel sizes will be reached at which distance. For optimal configuration of the camera there are various lenses available. Wide angle lenses have radial distortion due to the angle of their aperture. The PIX Connect software has an algorithm which corrects this distortion.

* Please note: Please use the optics calculator on our website in order to calculate measurement fields with shorter measurement distances:

<https://www.optris.global/optics-calculator>

The measurement accuracy of the camera may lie outside of the specifications for distances below the defined minimum measurement distance.

PI 160 / 200 160 x 120 px	Focal length [mm]	Minimum measurement distance*	Angle	Distance to measurement object [m]												
					0.02	0.1	0.2	0.3	0.5	1	2	4	6	10	30	100
O23 Standard lens	10	0.2 m	23°	HFOV [m]	0.012	0.043	0.08	0.12	0.21	0.41	0.81	1.62	2.44	4.1	12.2	40.6
			17°	VFOV [m]	0.009	0.032	0.06	0.09	0.15	0.30	0.60	1.21	1.81	3.0	9.0	30.1
			29°	DFOV [m]	0.015	0.054	0.10	0.16	0.26	0.51	1.01	2.02	3.03	5.1	15.2	50.5
			2.48 mrad	IFOV [mm]	0.1	0.3	0.5	0.8	1.3	2.5	5.0	9.9	14.9	24.8	74.4	248.0
O6 Telephoto lens	35.5	0.5 m	6°	HFOV [m]					0.06	0.11	0.23	0.45	0.68	1.1	3.4	11.3
			5°	VFOV [m]					0.04	0.09	0.17	0.34	0.51	0.8	2.5	8.5
			8°	DFOV [m]					0.07	0.14	0.28	0.57	0.85	1.4	4.2	14.2
			0.70 mrad	IFOV [mm]					0.4	0.7	1.4	2.8	4.2	7.0	21.1	70.4
O48 Wide angle lens	5.7	0.2 m	41°	HFOV [m]	0.022	0.082	0.16	0.23	0.38	0.76	1.51	3.00	4.50	7.5	22.5	74.9
			31°	VFOV [m]	0.016	0.059	0.11	0.17	0.28	0.55	1.10	2.19	3.28	5.5	16.4	54.5
			51°	DFOV [m]	0.027	0.101	0.19	0.29	0.47	0.94	1.86	3.72	5.57	9.3	27.8	92.7
			4.39 mrad	IFOV [mm]	0.1	0.4	0.9	1.3	2.2	4.4	8.8	17.5	26.3	43.9	131.6	438.6
O72 Wide angle lens	3.3	0.2 m	72°	HFOV [m]	0.039	0.152	0.29	0.43	0.72	1.42	2.84	5.66	8.49	14.1	42.4	141.4
			52°	VFOV [m]	0.027	0.106	0.20	0.30	0.50	0.99	1.98	3.95	5.92	9.9	29.6	98.6
			89°	DFOV [m]	0.048	0.186	0.36	0.53	0.87	1.74	3.46	6.91	10.35	17.2	51.7	172.3
			7.51 mrad	IFOV [mm]	0.2	0.8	1.5	2.3	3.8	7.5	15.0	30.0	45.0	75.1	225.2	750.8

PI 400i / 450i PI 450 G7 382 x 288 px	Focal length [mm]	Minimum measurement distance*	Angle	Distance to measurement object [m]												
					0.02	0.1	0.2	0.3	0.5	1	2	4	6	10	30	100
O29 Standard lens	13	0.35 m	29°	HFOV [m]		0.057	0.111	0.16	0.27	0.53	1.06	2.1	3.2	5.3	15.7	52.5
			22°	VFOV [m]		0.042	0.081	0.12	0.20	0.40	0.80	1.6	2.4	4.0	11.9	39.6
			37°	DFOV [m]		0.071	0.137	0.20	0.34	0.67	1.32	2.6	4.0	6.6	19.7	65.7
			1.3 mrad	IFOV [mm]		0.1	0.3	0.4	0.7	1.3	2.7	5.4	8.0	13.4	40.2	133.9
O13 Telephoto lens	20	0.45 m	18°	HFOV [m]			0.066	0.099	0.16	0.33	0.65	1.3	1.9	3.2	9.7	32.4
			14°	VFOV [m]			0.050	0.075	0.12	0.25	0.49	1.0	1.5	2.5	7.4	24.6
			23°	DFOV [m]			0.083	0.124	0.20	0.41	0.82	1.6	2.4	4.1	12.2	40.7
			0.9 mrad	IFOV [mm]			0.2	0.3	0.4	0.9	1.7	3.5	5.2	8.6	25.9	86.3
O53 Wide angle lens	8	0.25 m	53°	HFOV [m]		0.103	0.20	0.30	0.50	1.0	2.0	4.0	5.9	9.9	29.6	98.6
			38°	VFOV [m]		0.073	0.14	0.21	0.35	0.70	1.4	2.8	4.1	6.9	20.7	68.9
			66°	DFOV [m]		0.127	0.25	0.37	0.61	1.22	2.4	4.8	7.2	12.0	36.1	120.3
			2.2 mrad	IFOV [mm]		0.2	0.4	0.7	1.1	2.2	4.4	8.8	13.2	21.9	65.8	219.4
O80 Super wide angle lens	6	0.2 m	80°	HFOV [m]	0.087	0.17	0.33	0.49	0.82	1.7	3.3	6.7	10.0	16.6	49.9	166.4
			54°	VFOV [m]	0.056	0.11	0.21	0.31	0.51	1.0	2.0	4.1	6.1	10.2	30.6	101.9
			96°	DFOV [m]	0.103	0.20	0.39	0.58	0.97	2.0	3.9	7.8	11.7	19.5	58.5	195.1
			3.0 mrad	IFOV [mm]	0.2	0.3	0.6	0.9	1.5	3.0	6.0	12.0	18.1	30.1	90.3	300.9

Optical data

OPTICS

PI 640 / PI 640 G 7 640 x 480 px	Focal length [mm]	Minimum measurement distance*	Angle	Distance to measurement object [m]											
					0.1	0.2	0.3	0.5	1	2	4	6	10	30	100
O33 Standard lens	18.7	0.2 m	33°	HFOV [m]	0.068	0.13	0.19	0.31	0.60	1.20	2.38	3.57	5.9	17.8	59.3
			25°	VFOV [m]	0.051	0.09	0.14	0.23	0.45	0.89	1.77	2.65	4.4	13.2	44.2
			41°	DFOV [m]	0.085	0.16	0.23	0.38	0.75	1.49	2.97	4.45	7.4	22.2	74.0
			0.91 mrad	IFOV [mm]	0.1	0.2	0.3	0.5	0.9	1.8	3.6	5.5	9.1	27.3	90.9
O15 Telephoto lens	41.5	0.5 m	15°	HFOV [m]				0.13	0.26	0.52	1.05	1.57	2.6	7.8	26.1
			11°	VFOV [m]				0.10	0.20	0.39	0.79	1.18	2.0	5.9	19.6
			19°	DFOV [m]				0.17	0.33	0.66	1.31	1.96	3.3	9.8	32.7
			0.41 mrad	IFOV [mm]				0.2	0.4	0.8	1.6	2.5	4.1	12.3	41.0
O60 Wide angle lens	10.5	0.2 m	60°	HFOV [m]	0.128	0.25	0.36	0.59	1.17	2.32	4.63	6.94	11.6	34.6	115.4
			45°	VFOV [m]	0.091	0.18	0.26	0.42	0.83	1.66	3.31	4.96	8.3	24.7	82.4
			75°	DFOV [m]	0.157	0.30	0.44	0.72	1.43	2.85	5.69	8.52	14.2	42.6	141.8
			1.62 mrad	IFOV [mm]	0.2	0.3	0.5	0.8	1.6	3.2	6.5	9.7	16.2	48.6	161.9
O90 Super wide angle lens	7.7	0.2 m	90°	HFOV [m]	0.220	0.43	0.63	1.03	2.03	4.04	8.06	12.07	20.1	60.3	200.8
			64°	VFOV [m]	0.138	0.27	0.39	0.64	1.27	2.53	5.05	7.57	12.6	37.8	125.9
			111°	DFOV [m]	0.260	0.50	0.73	1.21	2.39	4.76	9.50	14.24	23.7	71.1	237.0
			2.21 mrad	IFOV [mm]	0.2	0.4	0.7	1.1	2.2	4.4	8.8	13.2	22.1	66.2	220.8

PI 1M / PI 08M ¹⁾ / PI 05M ¹⁾ 382 x 288 px	Focal length [mm]	Minimum measurement distance*	Angle	Distance to measurement object [m]											
					0.1	0.2	0.3	0.5	1	2	4	6	10	30	100
OF16	16	0.2 m	20°	HFOV [m]		0.07	0.11	0.18	0.36	0.72	1.43	2.15	3.6	10.7	35.8
			15°	VFOV [m]		0.05	0.08	0.14	0.27	0.54	1.08	1.62	2.7	8.1	27.0
			25°	DFOV [m]		0.09	0.13	0.22	0.45	0.90	1.79	2.69	4.5	13.5	44.9
			0.94 mrad	IFOV [mm]		0.2	0.3	0.5	0.9	1.9	3.8	5.6	9.4	28.1	93.8
OF25	25	0.5 m	13°	HFOV [m]	0.023	0.05	0.07	0.11	0.23	0.46	0.92	1.38	2.3	6.9	22.9
			10°	VFOV [m]	0.017	0.03	0.05	0.09	0.17	0.35	0.69	1.04	1.7	5.2	17.3
			16°	DFOV [m]	0.029	0.06	0.09	0.14	0.29	0.57	1.15	1.72	2.9	8.6	28.7
			0.60 mrad	IFOV [mm]	0.1	0.1	0.2	0.3	0.6	1.2	2.4	3.6	6.0	18.0	60.0
OF50	50	1.5 m	7°	HFOV [m]				0.06	0.11	0.23	0.46	0.69	1.1	3.4	11.5
			5°	VFOV [m]				0.04	0.09	0.17	0.35	0.52	0.9	2.6	8.6
			8°	DFOV [m]				0.07	0.14	0.29	0.57	0.86	1.4	4.3	14.4
			0.30 mrad	IFOV [mm]				0.2	0.3	0.6	1.2	1.8	3.0	9.0	30.0
OF75	75	2.0 m	4°	HFOV [m]					0.08	0.15	0.31	0.46	0.8	2.3	7.6
			3°	VFOV [m]					0.06	0.12	0.23	0.35	0.6	1.7	5.8
			5°	DFOV [m]					0.10	0.19	0.38	0.57	1.0	2.9	9.6
			0.20 mrad	IFOV [mm]					0.2	0.4	0.8	1.2	2.0	6.0	20.0

Table with examples showing which measurement field sizes and pixel sizes will be reached at which distance. For optimal configuration of the camera there are various lenses available. Wide angle lenses have radial distortion due to the angle of their aperture. The PIX Connect software has an algorithm which corrects this distortion.

* Please note: Please use the optics calculator on our website in order to calculate measurement fields with shorter measurement distances:

<https://www.optris.global/optics-calculator>

The measurement accuracy of the camera may lie outside of the specifications for distances below the defined minimum measurement distance.

¹⁾ PI 05M and PI 08M only available with OF25 lens

PI 1M / PI 08M ¹⁾ / PI 05M ¹⁾	Focal length [mm]	Minimum measurement distance*	Angle	Distance to measurement object [m]											
					0.1	0.2	0.3	0.5	1	2	4	6	10	30	100
764 x 480 px	16	0.2 m	39°	HFOV [m]		0.14	0.21	0.36	0.72	1.43	2.87	4.30	7.2	21.5	71.6
			25°	VFOV [m]		0.09	0.14	0.23	0.45	0.90	1.80	2.70	4.5	13.5	45.0
			46°	DFOV [m]		0.17	0.25	0.42	0.85	1.69	3.38	5.08	8.5	25.4	84.6
			0.94 mrad	IFOV [mm]		0.2	0.3	0.5	0.9	1.9	3.8	5.6	9.4	28.1	93.8
OF25	25	0.5 m	26°	HFOV [m]	0.046	0.09	0.14	0.23	0.46	0.92	1.83	2.75	4.6	13.8	45.8
			16°	VFOV [m]	0.029	0.06	0.09	0.14	0.29	0.58	1.15	1.73	2.9	8.6	28.8
			30°	DFOV [m]	0.054	0.11	0.16	0.27	0.54	1.08	2.17	3.25	5.4	16.2	54.1
			0.60 mrad	IFOV [mm]	0.1	0.1	0.2	0.3	0.6	1.2	2.4	3.6	6.0	18.0	60.0
OF50	50	1.5 m	13°	HFOV [m]				0.11	0.23	0.46	0.92	1.38	2.3	6.9	22.9
			8°	VFOV [m]				0.07	0.14	0.29	0.58	0.86	1.4	4.3	14.4
			15°	DFOV [m]				0.14	0.27	0.54	1.08	1.62	2.7	8.1	27.1
			0.30 mrad	IFOV [mm]				0.2	0.3	0.6	1.2	1.8	3.0	9.0	30.0
OF75	75	2.0 m	9°	HFOV [m]					0.15	0.31	0.61	0.92	1.5	4.6	15.3
			5°	VFOV [m]					0.10	0.19	0.38	0.58	1.0	2.9	9.6
			10°	DFOV [m]					0.18	0.36	0.72	1.08	1.8	5.4	18.0
			0.20 mrad	IFOV [mm]					0.2	0.4	0.8	1.2	2.0	6.0	20.0

¹⁾ PI 05M and PI 08M only available with OF25 lens

Microscope optics	Focal length [mm]	Minimaler Messabstand*	Angle	Distance to measurement object [m]			
					0.08	0.09	0.1
PI 640 640 x 480 px	44.2	0.08 m	12°	HFOV [m]	0.018	0.021	0.023
			9°	VFOV [m]	0.014	0.016	0.017
			15°	DFOV [m]	0.023	0.026	0.029
			0.36 mrad	IFOV [mm]	0.028	0.032	0.036
MO44 Microscope optics	44.2	0.08 m	12°	HFOV [m]	0.018	0.021	0.023
			9°	VFOV [m]	0.014	0.016	0.017
			15°	DFOV [m]	0.023	0.026	0.029
			0.36 mrad	IFOV [mm]	0.028	0.032	0.036

Microscope optics	Focal length [mm]	Minimum measurement distance*	Angle	Distance to measurement object [m]			
					0.09	0.1	0.11
Xi 400 382 x 288 px	20	0.09 m	18°	HFOV [m]	0.031	0.034	0.037
			14°	VFOV [m]	0.024	0.026	0.028
			23°	DFOV [m]	0.039	0.043	0.047
			0.9 mrad	IFOV [mm]	0.08	0.09	0.10
F20 CF Microscope optics	20	0.09 m	18°	HFOV [m]	0.031	0.034	0.037
			14°	VFOV [m]	0.024	0.026	0.028
			23°	DFOV [m]	0.039	0.043	0.047
			0.9 mrad	IFOV [mm]	0.08	0.09	0.10

innovative infrared technology

Optris GmbH
Ferdinand-Buisson-Str. 14
13127 Berlin · Germany
Tel.: +49 (0)30 500 197-0
Fax: +49 (0)30 500 197-10
E-Mail: info@optris.global
www.optris.global