

# MCT4 - 1/4 DIN Controller

A 1/4 DIN multi-loop controller that operates like your favorite smartphone or tablet



EASY TO USE  
TOUCH SCREEN  
INTERFACE

Combines multiple control and monitor components into an easy to use, 1/4 DIN low cost solution.



Touch screen-programmable right out of the box!

- + PC software is NOT required
- + LAN/USB/Cloud import/export configuration
- + One button return to OEM configuration

- Up to 3 PID loops - 1 may be FM Limit
- Paperless recorder/data logger
- Trend viewer/data viewer
- File transfer/backup via LAN/WAN/Cloud. Configure via USB memory stick or cloud.
- Email/SMS on alarm
- Remote access
- NEMA 4X / IP 65
- Math/Logic/Timers
- Up to 8 monitor points

## Simplicity

- + Touch screen, Slide Nav, menu, touch list user interface with Help on every view
- + Enable only those features required for the application; i.e. Profile, Data Log, Security, Connectivity, etc.
- + 64 step profiler with 8GB storage. "One Touch" profile entry with touch scroll lists and dynamic icon menus to eliminate costly learning curves.
- + Multi-lingual interface supports 11 languages – selectable by the touch of a button.

# MCT4 - 1/4 DIN Controller

## All the functionality of multiple devices in an easy to use low cost controller

The MCT4 system combines multiple control and monitor components in a single device. The 4.3" color touch screen allows users to select PC type menu or smart device slide-nav icon navigation to match familiar personal preferences for operation. Secure email (SSL/TLS), SMS (text messaging), FTP, FileWeb and DataWeb/Cloud protocols allow the MCT4 to interface and backup data to LAN/WAN/Cloud based systems and data bases, eliminating the need for additional data acquisition equipment. Math/Logic/Timer functions included as standard to reduce additional system components.

The MCT4 is equipped with a Web server and remote control via VNC from any smart device (smartphone/tablet/PC, etc.). Single touch notification provides loop, alarm, profile and system information in a simple touch scroll list from any screen location. All software functions are standard, no options to pay extra for!

### Flexibility

- + Up to 3 loops of control, 8 point monitor option, supports static, profile and cascade control modes. 1 loop may be FM limit.
- + Up to 19 programmable alarms (9 relays, 10 soft) for flexible control management.
- + 4 level security with digitally signed audit trails and data files.
- + User configurable datalogging and historical data viewer.
- + Meets data acquisition requirements:
  - CFR21 Part 11
  - AMS 2750F

### Connectivity

- + Email (SSL/TLS), SMS, FTP, FileWeb, DataWeb (SQL compatible) , VNC, NTS and Web page are all standard.
- + Remote View/Control using PC, Tablet or Smartphone via VNC.
- + Email/SMS on alarm, email files or send an email.
- + National Time Server (NTS) eliminates setting time/date manually.
- + Serial and TCP/IP Modbus RTU.
- + Math/Logic/Timers with direct IO control.

## Loop Overview

The MCT4 allows up to 3 plug-in slots for static, program or cascade control. An FM approved hi-limit module can be installed in slots 2 or 3. The MCT4's multi-processor design provides a "no wait" response for instantaneous screen and control operations.



## MCT4 - Base Specifications

### POWER

90-250VAC, 47-63 Hz, 36VA, 15W max  
11-26VAC/VDC, 36VA, 15W max

### DISPLAY

Display Type: TFT color touch display  
Display Size: 4.3"  
Display Colors: 65,536  
Resolution: 480 X 272  
Display lifetime hours (nominal): 30,000  
Type: Resistive Analog - IP65

### DISPLAY PROCESSOR

Type: PV210 CPU/1GHZ

### DIMENSIONS/PANEL CUTOUT

Dimensions: 122(W) x 100(H) x 122.85(D)  
mm Panel Cutout: 91(W) x 91(H) mm

### PLUG IN CONTROL/LIMIT MODULES

Process Control Module (PCM)  
Hi-Limit Module (HLM)

*\*See Order Matrix for Details*

### DATA STORAGE

256MB Internal Flash  
8GB SD (SLC) for file storage

### CONNECTIVITY

Serial: Com1 (RS232/485), Com2 (RS485)  
Ethernet: 10\100 baseT - USB: 1 host  
Modbus Master and Slave Protocols  
(Serial and Ethernet TCP/IP Modbus slave protocols available simultaneously)

### ENVIRONMENTAL AND PHYSICAL

Storage Temperature: -20 to 60 C  
Operating Temperature: 0 to 50 C  
Humidity: 10% to 90%, no condensation  
Shock: 3 shocks per direction 11ms 10g  
Vibration: 10 to 25.7 Hz: 0.75mm amplitude 25.7 to 150Hz: 1g 1oct/min. 10 sweeps  
Insulation: 20M ohms minimum (500VDC)  
Dielectric Strength: 2300Vac 50/60 Hz for 1 minute between power terminal and earth  
Approval Standards: NEMA 4X/IP65  
UL, cUL, CE, RoHS, W.E.E.E, FM (high limit)

## Touch Screen User Interface

4.3" touch screen operates like your favorite smart phone or tablet. Menu or slide-navigation allows the user to treat screens, options and functionality like "apps" on their PC or favorite smart device. Familiar gestures like touch scroll lists (text or text with buttons) and notifications provide instant access to all system data from any screen for quick entry and selection of control functions. Standard toolbar provides common access to menus, help, home, alarms and notifications from all screens.

### Menu Navigation

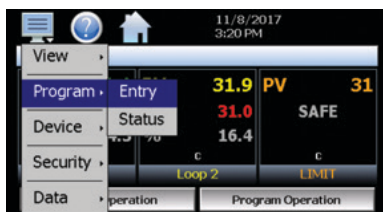

### Icon/Page Navigation



### Notification/Touch Lists

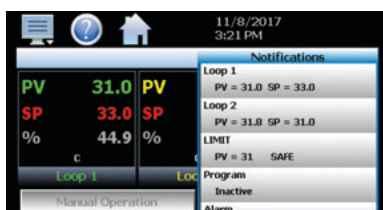

### Content Sensitive Help on every view

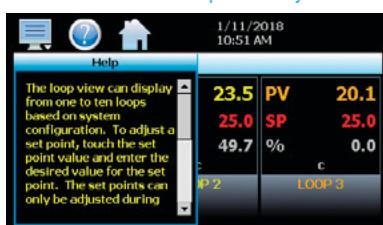

## Process Control Module

### (LOOP CONTROL)

Up to 3 loops of control, with up to 4 outputs per process control module. Control logic includes static, profile and cascade control with adaptive fuzzy logic and PID control (5 sets) for each control loop module. Multi-processor design provides immediate response for control and touch screen operations.

## High Limit Module

### FM APPROVED LIMIT SAFETY

The HLM module provides an FM approved high, low or high/low limit safety in slots 2 or 3 of the MCT4. The second alarm output available on each HLM module provides the flexibility of programmable alarm logic to meet specific needs. A loop control and FM limit in one solution eliminates extra hardware to reduce hardware costs and panel space requirements.

### Process Control Module (PCM)

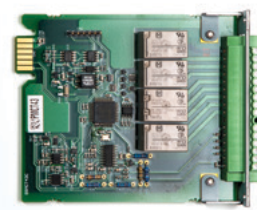

Up to 3 loops static, dual loop profile.

### High-Limit Module (HLM)

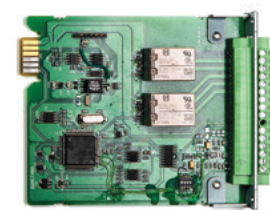

Can be installed with single or dual loop system.

# “ONE TOUCH” Profile Program Entry

## PROGRAM ENTRY IS QUICK AND EASY

The MCT4 provides program entry operations on a single screen. Touch scroll lists and menu icons provide dynamic operations based on user selections. Simple on/off buttons within the scroll lists eliminates navigating through multiple screens to complete program entry tasks.

64 programmable steps include ramp, soak, jump and jump cycles. Loop setpoints, step events, step hold/wait for and repeat functions provide advanced program functionality with unlimited program storage (limited only by 8GB of memory).

Copy and paste functions allow quick entry of step data as well as copying step events to all remaining program steps to reduce complex program tasks.

Slide out numeric keypads and program control windows allow the user to maintain view of the background window to reduce screen clutter. Transparent dialogs and pop-up menus provide quick operations for all profile functions without leaving the main profile entry screen.

Profile run status is available in detail or from loop and overview screens as well as notification drop down touch lists which are available on all of the MCT4 runtime screens.

The help icon in the command bar provides context sensitive information for all views including Profile Program Entry.

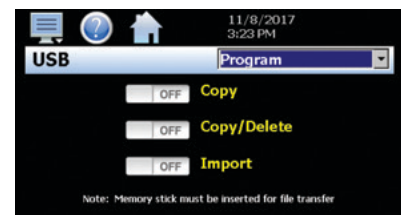
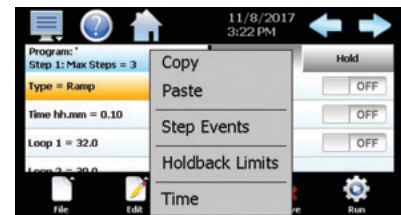
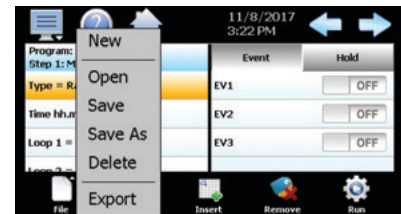

USB  
import/export  
of profiles

## Data Logging

The MCT4 supports data logging of all process variables with 8GB of storage standard. Filename, lot number, batch number, log interval and days to log are all configurable from the front touch screen. Program log control allows the user to start/stop logging using the automated programmer with the program name used as the datalog name. "Always Logging" startup option provides the ability to enable the MCT4 to log at all times to maintain 24/7 logging operation. The "Days To Log" option allows the user set the time in days before a new file is started to sync data files to match product cycles as well as keeping data file size manageable.

### Configurable Datalog

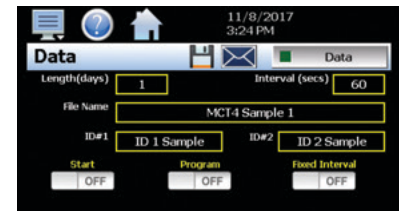

## Historical Data Viewer

MCT4 includes a historical data viewer that allows trend chart viewing of data files stored on the device (8GB max). Selection of data points, data start/end time along with drag and zoom trend options (with legends) provide a quick and easy view of any batch run for any date and time.

### Historical Viewer

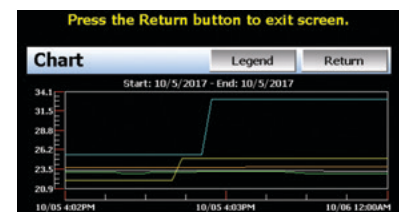

## Digital Signatures

MCT4 data files and audit trails are digitally signed to maintain data integrity and meet regulatory requirements for digital (vs. paper) operation. This is different from data file encryption since the digital signature protects the file from being altered in any way. Additional signatures (unlimited) can be added by authorized users along with text to describe the signature (i.e. batch passed, setpoint change, etc.). Meets the requirements for data acquisition for CFR21 Part 11 and AMS 2750F

### Digital Signatures

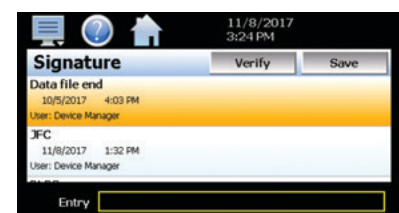

## Chart Trend View

Four real time charts configurable to display any variable in the controller (up to 6 values per view) over a selectable time period of 4-minutes to 24 hours. With configurable left and right axis, automatic or defined chart scales and finger pinch on the fly zoom, the 4 configurable charts allow an operator a 1-button touch to view recent process history without opening a data log file.

### Chart Trend View

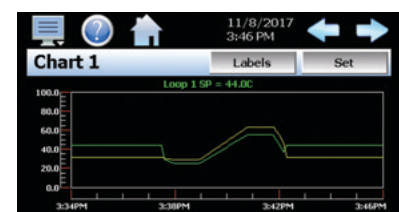

## User-Based Security

MCT4 includes an easy to configure, full user based/user rights security for system, user, supervisor and administrative levels. Up to 30 users supported with each user having the option of type assignment (user, supervisor, etc.). Each function in the MCT can be enabled or disabled for each user type. The user decides which options each user type has access to rather than a “number” based system which can include functions not desired for most “process secure” operations.

### User-Based Security

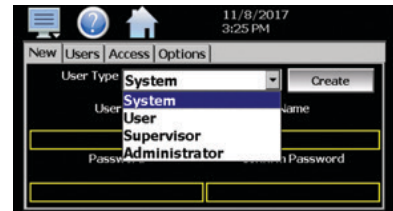

## Password Aging and Verification

Password aging, auto log off and user re-verification provides the flexibility and security required for regulated processes.

### Password Aging and Verification



## Audit Trail Entries

MCT4 includes full audit trail entries for all user activity. Any process change must pass the security check and is written to the audit trail. Audit trail includes date, time, user name and user action. (example: Loop1 setpoint change from 21.0 to 23).

### Audit Trails



## Mechanical and Soft Alarms

Each PCM supports up to 3 mechanical alarms with the HLM supporting up to one mechanical alarm. Alarm types include process high/low, deviation high/low, deviation band, end of program and digital input. An additional 10 software alarms can be assigned as PCM IO outputs or GUI alarms. Inhibit, Silent, Email and Ring Back standard for all software alarms with each soft alarm providing a programmable “delay time” setting.

## Math/Logic/Timers

MCT4 includes up to 20 Math/Logic/Timer blocks. Free form math equation entry up to 200 characters per block. Logic/Timer blocks can be assigned directly to PCM IO for direct logic control operations.



## Loop Control and Monitor Only Operation

Any of the MCT4 input modules can be configured for loop control or monitor only. This provides the ability to easily add a monitor point while the MCT4 dynamically configures it's setup for "monitor only" view and operation; setpoint & percent output are not shown. Monitor loops support process alarms.

## Dynamic Screens/Options Configuration

The MCT4 includes all software features as standard. No options to purchase. All functionality can be enabled or disabled right from the configurator application from the front touch screen. This allows users to configure the MCT4 to meet their specific requirements without external PC's, cables, routers or additional software to learn, minimizing service and support costs.

## Profile Program Entry And Control

The MCT4 includes an advanced profiler with ramp, soak, jump, cycle, hold and event functions for each step. Up to 64 steps per profile with a virtually unlimited number of profiles included as standard (8GB max). "One Touch" program entry provides all functions on a single screen using familiar touch scroll lists for setpoint entry and option settings. Program slide out windows allow the user to select and operate programs without losing focus on the background window which reduces screen clutter and learning curves.

## Email/SMS

MCT4 supports secure email client functionality (Secure Socket Layer/Transport Layer Security/None). Alarms can be automatically configured to be sent as an email or text notification as well as end of automated program notices. Send alarm, audit and data files as attachments.

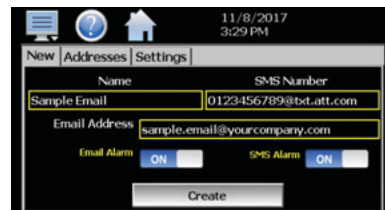

## Import/Export Configurations

MCT4 includes full import and export of complete controller configurations using a standard USB memory device or via LAN/cloud transfer (free PC software or cloud service at fdcUtil.com). Saved configurations can be imported to any MC4 for complete setup in minutes. This eliminates searching for manuals or long configuration setups for new installations or maintenance situations. Cloud configurations are encrypted and digitally signed to provide enhanced security for industrial applications.

An OEM may set their configuration as the MC4 "Default Configuration". When so configured this provides an end user a 1-button touch to reset the unit to an OEM's configuration saving both the user and OEM downtime and support costs.

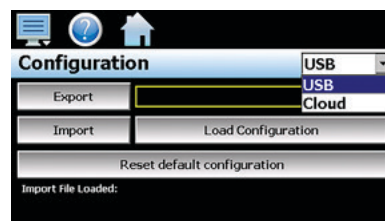

# File Management

## LAN/WAN/CLOUD PROTOCOLS

MCT4 includes FTP (File Transfer Protocol) and FileWeb transfer (https:// encrypted communications) of all file data from the controller. DataWeb protocols allow the MCT4 to transfer real time/historical process information to secure data bases via LAN, WAN or Cloud based manufacturing systems using standard SQL (Structured Query Language) data interfaces . This eliminates the need for additional data acquisition or network hardware.

## USB/LAN/CLOUD BACKUP AND CONFIGURATION

File transfer utilities allow export of all data to a standard USB memory device, LAN or Cloud storage (configurations free at [fdcUtil.com](http://fdcUtil.com)). Internal memory can be cleared after export to provide "maintenance free" storage operation.

# 8 Monitor Points (optional IO card)

The MCT4 supports up to 8 additional monitor inputs (each input programmable for TC/Volts/mA). Monitor card is DIN rail mount with 2 wire RS485 connectivity. See monitor card brochure for details.

# 11 Languages Supported For Global Usage

MCT4 provides instant selection of 11 languages providing global usage for shipment anywhere in the world (no reboot or special order codes required). Chinese Simplified, Chinese Traditional, English, French, German, Italian, Japanese, Korean, Portuguese, Russian and Spanish supported with a single touch.

# Remote Control/Monitor from PC/SmartPhone/Tablet

MCT4 includes a remote VNC server for remote monitor or control and a monitor only web server from any smart device anywhere, anytime.

FTP | FileWeb | DataWeb



File Management

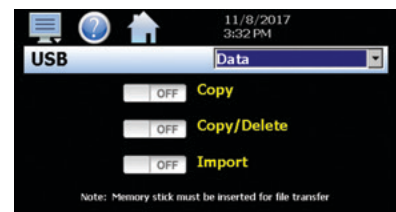

Languages

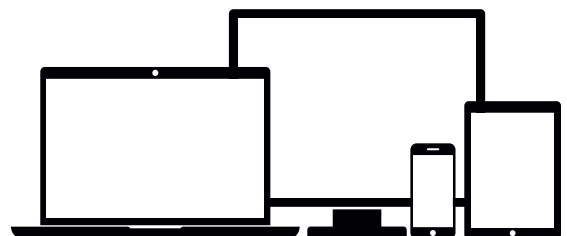
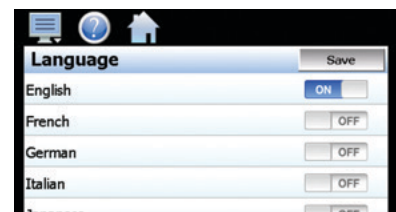

# Process Control (PCM) and Hi-limit (HLM) Module Specification

## INPUT SPECIFICATIONS\*

Type	Range	Accuracy @ 24 C	Input Impedance
J	-120 C 1000 C (-184 F 1832 F)	+/-2 C	2.2 Mohms
K	-200 C 1370 C (-328 F 2498 F)	+/-2 C	2.2 Mohms
T	-250 C 400 C (-418 F 752 F)	+/-2 C	2.2 Mohms
E	-100 C 900 C (-148 F 1652 F)	+/-2 C	2.2 Mohms
B	0 C 1820 C (-32 F 3308 F)	+/-2 C (200-1820 c)	2.2 Mohms
R	0 C 1767.8 C (-32 F 3214 F)	+/-2 C	2.2 Mohms
S	0 C 1767.8 C (-32 F 3214 F)	+/-2 C	2.2 Mohms
N	-250 C 1300 C (-418 F 2372 F)	+/-2 C	2.2 Mohms
L	-200 C 900 C (-328 F 1652 F)	+/-2 C	2.2 Mohms
C	0 C 2315 C (32 F 4199 F)	+/-2 C	2.2 Mohms
P	0 C 1395 C (32 F 2543 F)	+/-2 C	2.2 Mohms
PT100 (DIN)	-210 C 700 C (-346 F 1292 F)	+/-0.4 C	1.3 Kohms
PT100 (JIS)	-200 C 600 C (-328 F 1112 F)	+/-0.4 C	1.3 Kohms
MV	-8mV 70mV	+/-0.05%	2.2 Mohms
MA	-3mV 27mA	+/-0.05%	70.5 Ohms
V	-1.3V 11.5V	+/-0.05%	302 Kohms

\*When subject to the necessary field calibration, the MCT4 is suitable for use in Nadcap applications in all furnace classes as defined in AMS2750F clause 3.3.1.

**Resolution:** 18 bits  
**Sampling Rate:** 5 times / second  
**Maximum Rating:** -2VDC minimum, 12VDC maximum  
 (1 minute for mA input)  
**Temperature Effect:** A1.5uV/ C for all inputs except mA input  
 A3.0uV/ C for mA input

**Sensor Lead Resistance Effect:**  
 T/C: 0.2uV/ohm  
 3-wire RTD: 2.6 C/ohm of resistance  
 difference of two leads  
 2-wire RTD: 2.6 C/ohm of resistance  
 sum of two leads

**Sensor Break Responding Time:**  
 Within 4 seconds for TC, RTD and mV inputs,  
 0.1 second for 4-20 mA and 1 - 5VDC inputs.

**Burn-out Current:** 200 nA

**Common Mode Rejection Ratio (CMRR):** 120dB

**Normal Mode Rejection Ratio (NMRR):** 55dB

**Sensor Break Detection:** Sensor open for TC, RTD and mV inputs,  
 Sensor short for RTD input  
 below 1 mA for 4-20 mA input,  
 below 0.25VDC for 1 - 5VDC input,  
 unavailable for other inputs.

**Electrical Isolation:** Optical isolation; 1500V~ (ac) minimum, between  
 input signals and power supply circuit.

## OUTPUT SPECIFICATIONS:

**Relay Rating:** 2A/240 VAC, life cycles 200,000 for resistive load

**Pulsed Voltage:** Source Voltage 5V @30mA, current limiting resistance 66 ohms  
 Source Voltage 14V@40mA, current limited at 70mA

### Linear Output (PCM):

Resolution: 15 bits  
 Output Regulation: 0.02% for full load change  
 Output Settling Time: 0.1 sec. (stable to 99.9%) Isolation  
 Breakdown Voltage: 1000 VAC  
 Temperature Effect: +/- 0.01% of span per degree C

### Analog Retransmission (PCM):

Output Signal: 4-20 mA, 0-20 mA,  
 0 - 5VDC, 1 - 5VDC, 0 - 10VDC  
 Resolution: 15 bits  
 Accuracy: +/-0.05% of span +/-0.0025%/ C Load  
 Resistance: 0 - 500 ohms (for current output)  
 10K ohms minimum (for voltage output)  
 Output Regulation: 0.01% for full load change  
 Output Settling Time: 0.1 sec. (stable to 99.9%)  
 Isolation Breakdown Voltage: 1000 VAC min. Integral  
 Linearity Error: +/-0.005% of span  
 Temperature Effect: +/-0.0025% of span per degree C  
 Saturation Low: 0 mA (or 0 VDC)  
 Saturation High: 22.2 mA (or 5.55VDC, 11.1VDC min)  
 Linear Output Range: 0-22.2mA (0-20mA or 4-20mA)  
 Volts DC: 0 - 5.55VDC (0 - 5VDC, 1 - 5VDC)  
 0 - 11.1VDC (0 - 10VDC)

## CONTROL FUNCTION (PCM):

**Control Action:** Direct and reverse

### Proportional Band:

Temperature: 0.1 to 500C (0.1 to 900F)  
 Linear Input: 0.1 to 900.0

**Reset (Auto):** 0 to 3600 seconds

**Rate (Derivative):** 0 to 900.0 seconds

**PB Offset:** 0 to 100%

### Dual PID Heat/Cool (bimodal):

Cool Proportional Band 50 to 300% of heat PB  
 Proportional Deadband -36.0% to +36.0% of heat PB

### Time Proportioning Cycle Time:

0.1 to 90 seconds

### On-Off / Alarm Hysteresis (PCM/HLM):

0.1 to 50C (0.1 to 90.0F)

## EVENT INPUT SPECIFICATIONS:

Logic Low: -10V minimum, 0.8V maximum  
 Logic High: 2V minimum, 10V maximum

## APPROVAL STANDARDS:

UL / cUL: UL 61010C-1  
 EN: EN 61010-1 (IRC-1010-1)  
 EMC: EMC 61326  
 RoHS: RoHS 2.0 Compliant, W.E.E.E.  
 FM (HLM): FM temperature limit switch - indicating

# SPECIFICATION AND FEATURE REVIEW

## COMMAND BAR ICONS NAVIGATION, HELP & HOME

The Main Command Bar located on the top of the display provides easy & intuitive 1-touch access from anywhere in the system to System Navigation, Help and configured Home view

Home brings the user back to the system "Home View". The Home icon can be configured for the following standard views;

- Loop view: includes PV & SP digital display, PV min/max, PID % Output, Auto-Manual, event & profile access and more.
- Overview: all loops, profile and event status
- Chart View (trend up to the last 24 hours from system RAM) supporting 4 Trend View charts with up to 6 values per chart
- Alarm View or Alarm File.

Help offers content sensitive text for every view / page in the user configured language.

Navigation provides access to the configured menu system, traditional drop down or icon.

## SECURITY AND AUDIT TRAIL:

- Supports up to 30 users over four user groups with access to 40+ functions restricted by user group.
- Supports password aging, auto log out and verification.
- Operator Audit Trail provides history for all user activity that includes date, time, user name and action; i.e. Loop SP change from 55.2 to 103.5.

## PROFILE RAMP/SOAK:

- Loop selectable for program/static/cascade
- Program Operation: Via touch screen or event input
- Profile Name: Free form 16 character naming convention.
- Global Profile Configuration:
  - Start from PV or static SP
  - Guaranteed Soak & Ramp band
  - Power Fail / Recovery: Continue from last SP value, PV or static mode.
- Profile Segments: (maximum of 64)
- Guaranteed Soak & Ramp per step
- Events: 3, 6 or 9 events per step (up to 3 events per PCM card).
- Jump-To Step: configurable per step
- Profile End Alarm
- Configurable Profile End Logic:
  - Current (Static) Control SP: the Set Point & Event status prior to Profile Start is loaded at end of the Profile.
  - Final SP of Profile with all Events off

## ALARMS

- Up to 19 alarms, 10 soft configurable to PCM & HLM, up to 3 alarm outputs per PCM and HLM up to 2 alarm outputs.

- Loop\* Alarm Types: Process High & Low, Deviation High & Low, Deviation Band, Event Input and End of Profile.

\* PCM configured as Monitor Input (no PID control configurable only with Process alarms).

### Alarm Mode:

Normal or Hold (on start-up Hold mode will not activate if in alarm condition and arm once out of alarm condition).

Silent Alarm, activation does not indicate alarm or write to alarm log file.

Alarm outputs configurable as latching or nonlatching.

## DATA ACQUISITION:

- All controller variables.
- File name: Free form 16 character appended by time/date or the profile name if started with a profile.
- File Start/Stop: user on-demand, on system boot or profile ramp-soak start/end.
- Data Log interval: configurable 2-second to 31-minutes.
- File Interval: configurable to set time in days (1 to 31) to end and start a new file. This allows syncing files to match product cycles as well as keeping file size manageable.
- ID#1 and ID#2 fields allow user to enter specific information such as a Batch/Lot/Cloud ID information that is associated with the data file.
- Operator Comments/Events: Unlimited operator comments/events linked to each file
- File Type: Data Log files are saved in .csv format.
- Digital Signatures: Automatic system as well as user entered signatures.
- Historical Data Viewer: View data log files on the display. Chart is auto-scaled on an X & Y axis for time and units.
- Meets the requirements for:
  - CFR21 Part 11
  - AMS2750F

## EVENT INPUTS

- PCM / HLM each have 1 event input that can be assigned to profile operations, screen update operations, soft alarm, math, logic and HLM reset operations

## DIMENSIONAL DRAWINGS AND PCM/HLM WIRING DIAGRAMS

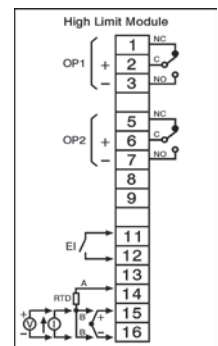
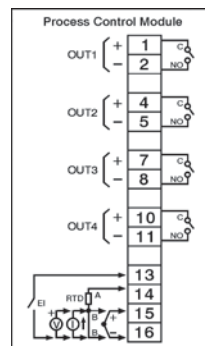
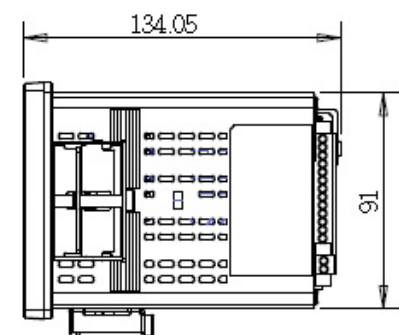
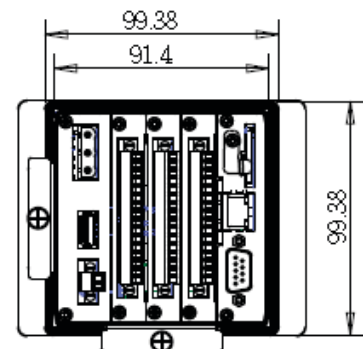
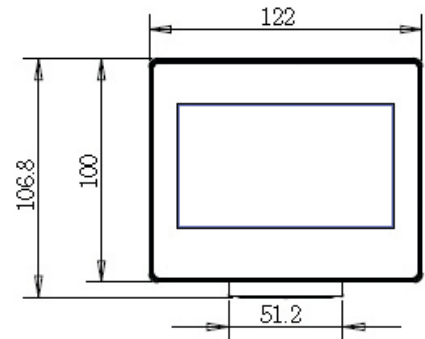

Enter a number in each box which corresponds to the specifications you want when ordering the MCT4 with PCM or HLM modules.



### SOFTWARE TYPE

- 01: MCT4 (SD-4MA)
- XX: Special Order Code

### POWER INPUT

- 4: 90-250VAC 50/60 HZ
- 5: 11-26VAC/VDC

### MODULE TYPE SLOT 1

- 0: None
- Pxxxx: Process Control Module (PCM Matrix)

### MODULE TYPE SLOT 2

- 0: None
- Pxxxx: Process Control Module (PCM Matrix)
- Hxxx: High Limit Module (HLM Matrix - if HLM in 2, slot 3 none)

### MODULE TYPE SLOT 3

- 0: None
- Pxxxx: Process Control Module (PCMAv Matrix - 0 only if HLM in slot 2)
- Hxxx: High Limit Module (HLM Matrix - 0 only if HLM in slot 2)

### DOCUMENTATION

- 0: None (available at [www.futuredesigncontrols.com](http://www.futuredesigncontrols.com))
- C: CD
- U: USB Memory Stick
- P: Printed Manual

### SPECIAL ORDER CODE

- 00: None
- XX: Special Order Code

## Part number examples:

#### MCT4-01-4-P1111-P1111-H111-000

MCT4 with 2 process control modules and a high limit module. Standard software. 90-250VAC 50/60 HZ. Each process control module (slot #1 and #2) is equipped with 4 relay outputs. Slot 3 has a high-limit module installed equipped with 2 relay outputs. No special order code.

#### MCT4-AB-5-P3311-H111-0-000

MCT4 with 1 process control module and a high limit module. Special software code "AB". 11-26VAC/VDC. PCM#1 module equipped with 4-20mA in outputs 1 and 2 and relays in outputs 3 and 4. Slot 2 has a high-limit module installed with 2 relay outputs. Slot3 is empty and not used. No special order code.

#### MCT4-01-4-P1111-0-0-0AN

MCT4 with 1 process control module. Standard software. 90-250VAC 50/60 HZ. Process control module (slot #1) is equipped with 4 relay outputs. Slot 2 and 3 are empty and not used. "AN" special order code.

# ORDERING INFORMATION

## PCM MATRIX

Enter a number in each box which corresponds to the hardware required when ordering the Process Control (PCM) Module.

P

PCM modules can be installed in slots 1, 2 or 3

### OUTPUT 1

- 0: None
- 1: Relay 2A/240VAC (Form A)
- 2: Pulsed voltage to drive SSR, 5V/30mA
- 3: 0-20mA/4-20mA isolated output (OM99-3)
- 4: 0-10V isolated output (OM99-5)
- C: Pulse voltage to drive SSR, 14V/40mA (OM99-7)

### OUTPUT 2

- 0: None
- 1: Relay 2A/240VAC (Form A)
- 2: Pulsed voltage to drive SSR, 5V/30mA
- 3: 0-20mA/4-20mA isolated output (OM99-3)
- 4: 0-10V isolated output (OM99-5)
- 7: Power supply 20VDC/25mA (DC99-1)
- 8: Power supply 12VDC/40mA (DC99-2)
- A: Power supply 5VDC/80mA (DC99-3)
- C: Pulse voltage to drive SSR, 14V/40mA (OM99-7)

### OUTPUT 3

- 0: None
- 1: Relay 2A/240VAC (Form A)
- 2: Pulsed voltage to drive SSR, 5V/30mA
- 7: Power supply 20VDC/25mA (DC99-1)
- 8: Power supply 12VDC/40mA (DC99-2)
- A: Power supply 5VDC/80mA (DC99-3)
- C: Pulse voltage to drive SSR, 14V/40mA (OM99-7)

### OUTPUT 4

- 0: None
- 1: Relay 2A/240VAC (Form A)
- 2: Pulsed voltage to drive SSR, 5V/30mA
- 3: Retransmit 0-20mA/4-20mA (OM99-3)
- 4: Retransmit 0-10VDC (OM99-5)
- 7: Power supply 20VDC/25mA (DC99-1)
- 8: Power supply 12VDC/40mA (DC99-2)
- A: Power supply 5VDC/80mA (DC99-3)
- C: Pulse voltage to drive SSR, 14V/40mA (OM99-7)

PCM Modules support Universal Analog Signal Inputs T/C-RTD, mA and VDC.  
Hardware configuration is via board DIP switch.  
Default hardware configuration is T/C-RTD

**HLM MATRIX** Enter a number in each box which corresponds to the hardware required when ordering the High-Limit (HLM) Module.

**H**

HLM modules can be installed in:  
 - slot 2 with 2-loop system  
 - slot 3 with 3-loop system

**SIGNAL INPUT\***

- 1: Thermocouple: J, K, T, E, B, R, S, N, L, C, P, PT100 DIN, PT100 JIS, 0-60mV
- 2: Voltage 0-1VDC
- 3: Voltage 0-10VDC
- 4: Current 0-20mA (4-20mA)
- 5: Voltage 0-5VDC (1-5VDC)

**OUTPUT 1**

- 1: Relay 2A/240VAC (Form C)
- 2: Pulsed voltage to drive SSR, 5V/30mA
- C: Pulse voltage to drive SSR, 14V/40mA (OM99-7)

**OUTPUT 2**

- 0: None
- 1: Relay 2A/240VAC (Form C)
- 2: Pulsed voltage to drive SSR, 5V/30mA
- 7: Power supply 20VDC/25mA (DC99-1)
- 8: Power supply 12VDC/40mA (DC99-2)
- A: Power supply 5VDC/80mA (DC99-3)
- C: Pulse voltage to drive SSR, 14V/40mA (OM99-7)

HLM signal input order code #1 supports analog input types T/C-RTD, mA, 0-10 VDC, 4-20/0-20mA. Hardware configuration for each input type is via DIP switch.

\*HLM configured with Signal Inputs 0-60mV, 0-1VDC, 0-5VDC, 0-10VDC or 4-20/0-20mA are NOT FM approved



**FUTURE DESIGN CONTROLS**

P.O. Box 1196

Bridgeview, IL 60455

888.751.5444

888.307.8014 Fax